

Contents

1. Description	
1.1 General Description	
1.2 Features	
1.3 Application	
1.4 Package Dimension	
1.5 Product Parameters	
1.6 Typical Optical Characteristics Curves	
2. Packaging	
2.1 Packaging Specification	
2.1.1 Carrier Tape Dimension	13
2.1.2 Reel Dimension	13
2.1.3 Label Form Specification	14
2.2 Moisture Resistant Packing	
2.3 Cardboard Box	
2.4 Reliability Test Items And Conditions	
2.5 Criteria For Judging Damage	
3. SMT Reflow Soldering Instructions SMT	
3.1 SMT Reflow Soldering Instructions SMT	
4. Handling Precautions	
4.1 Handling Precautions	

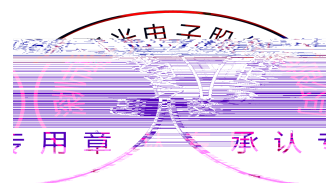

The Colour LED which was fabricated using blue green and red chip Package Dimension :
3.2mmX2.7mmX0.7mm.

3.2mmX2.7mmX0.7mm

Extremely wide view angle.
Suitable for all SMT assembly and solder process.
Moisture sensitivity level 1

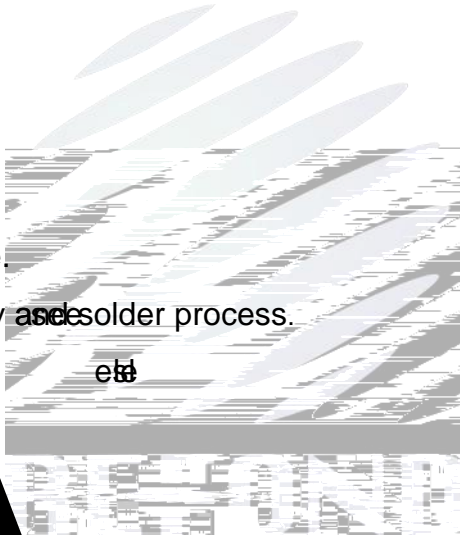

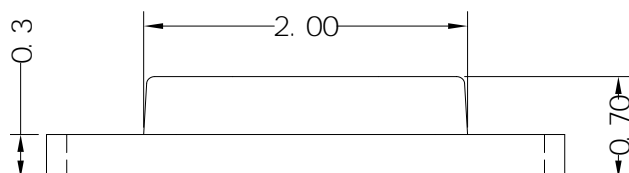

Fig.1-2 Side view

Fig.1-1 Top view



Fig.1-3 Bottom view

Fig.1-4 Polarity

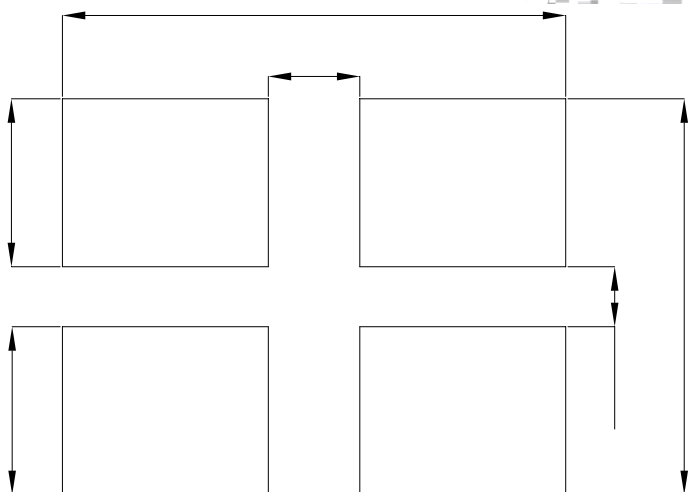
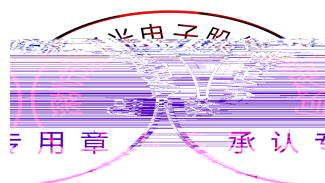

Fig.1-5 Soldering patterns



Notes

All dimensions units are millimeters.

All dimensions tolerances are $\pm 0.2\text{mm}$ unless otherwise noted.

Table 1-1 Electrical / Optical Characteristics at $T_s=25^\circ\text{C}$

Item	Test Condition	Symbol	Code	Value			Unit	
				Min. ()	Typ.	Max.		
Spectral Half Bandwidth	$I_F=20\text{mA}$		R	--	15	--	nm	
			G	/	--	30		--
			B	--	30	--		
Forward Voltage	$I_F=20\text{mA}$	V_F	R 1L	1.8	--	2.4	V	
			G 3F	2.8	--	3.4		
			B 3F	2.8	--	3.4		
Dominant wavelength	$I_F=20\text{mA}$	d	R	G00	630	--	635	nm
				H00	635	--	640	
			G	D10	515	--	517.5	
				D20	517.5	--	520	
				E10	520	--	522.5	
				E20	522.5	--	525	
			B	D10	465	--	467.5	
				D20	467.5	--	470	
				E10	470	--	472.5	
				E20	472.5	--	475	

Luminous Intensity	I _F =20mA	I _v	R	1BS	40	--	90	mcd
			G	1AU	260	--	330	
				1AV	330	--	430	
				1CG	430	--	560	
				1CL	560	--	700	
				1CM	700	--	900	
			B	1DM	60	--	90	
				1AP	90	--	120	
				G20	120	--	150	
				1AW	150	--	200	
				1GK	200	--	260	
Viewing Angle	I _F =20mA	2 1/2	--	140	--	deg		
Reverse Current	V _R =5V	I _R	--	--	10	μA		
Thermal Resistance.	I _F =20mA	R _{THJ-S}	--	--	450	/W		

Notes : V_R=5V For test conditions. V_R=5V

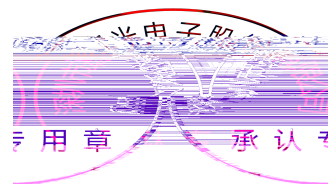

Table 1-2 Absolute Maximum Ratings at Ts=25°C

Parameter	Symbol	Rating			Units
		R	G	B	
Power Dissipation	P_d	48	68	68	mW
Forward Current	I_F	20			mA
Peak Forward Current Of Pulse	I_{FP}	60			mA
Electrostatic Discharge (HBM)	E_{SD}	1000			V
Operating Temperature	T_{opr}	-40 ~ +85			
Storage Temperature	T_{stg}	-40 ~ +85			
Junction Temperature	T_j	95			

Notes

- 1/10 Duty cycle, 0.1ms pulse width.
- The above forward voltage measurement allowance tolerance is $\pm 0.1V$.
- The above dominant wavelength measurement allowance tolerance is $\pm 2nm$.
- The above luminous intensity measurement allowance tolerance $\pm 10\%$.
- Care is to be taken that power dissipation does not exceed the absolute maximum rating of the product.
- All measurements were made under the standardized environment of Refond.
- When the LEDs are in operation the maximum current should be decided after measuring the package temperature, junction temperature should not exceed the maximum rate

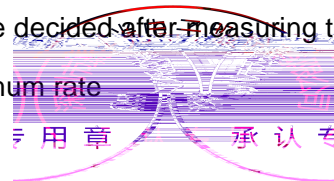
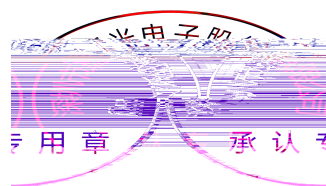



Fig.1-6



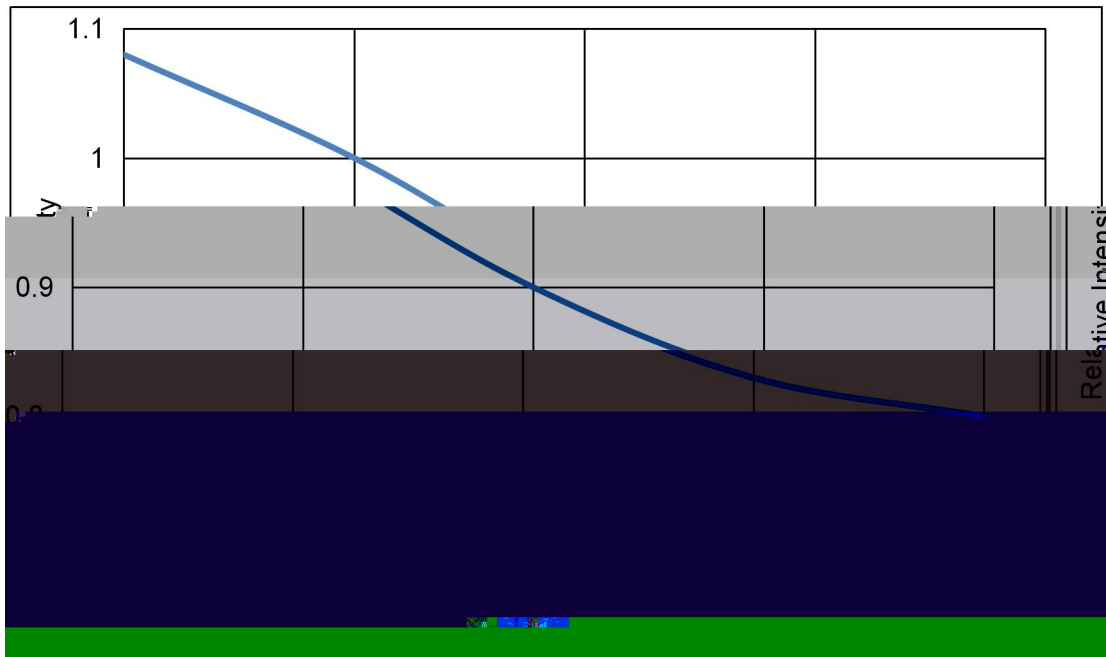

Fig.1-8 Pin Temperature Vs Relative Intensity

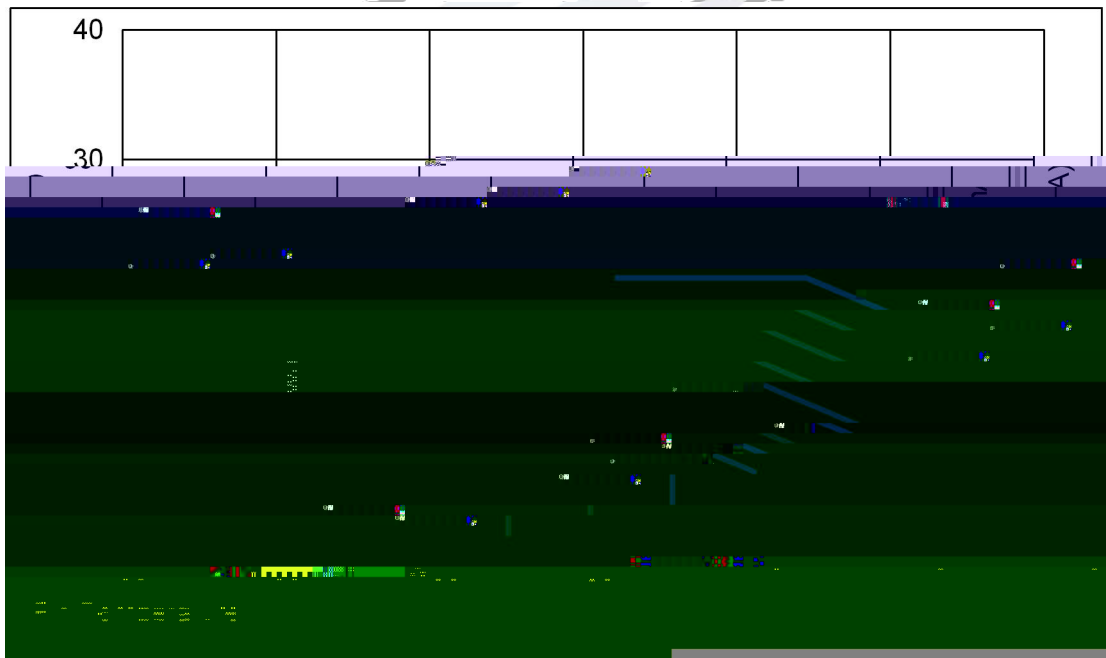
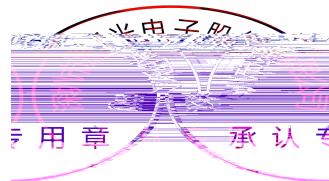

Fig.1-9 Pin Temperature Vs Forward Current



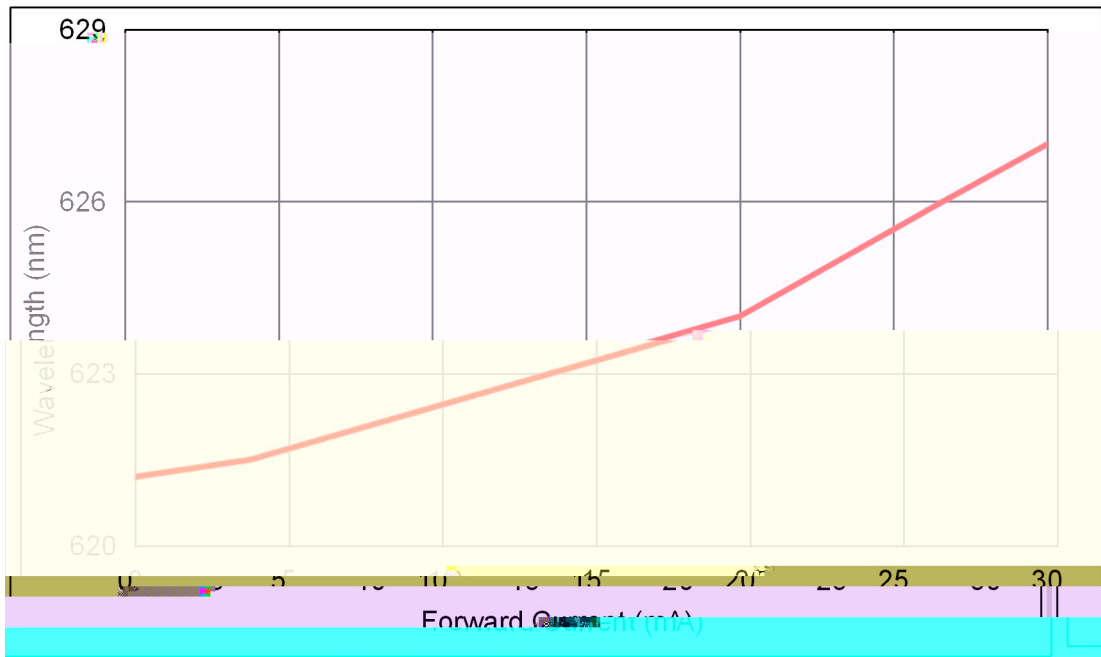

Fig.1-10 Forward Current Vs Dominate Wavelength (Ta=25)

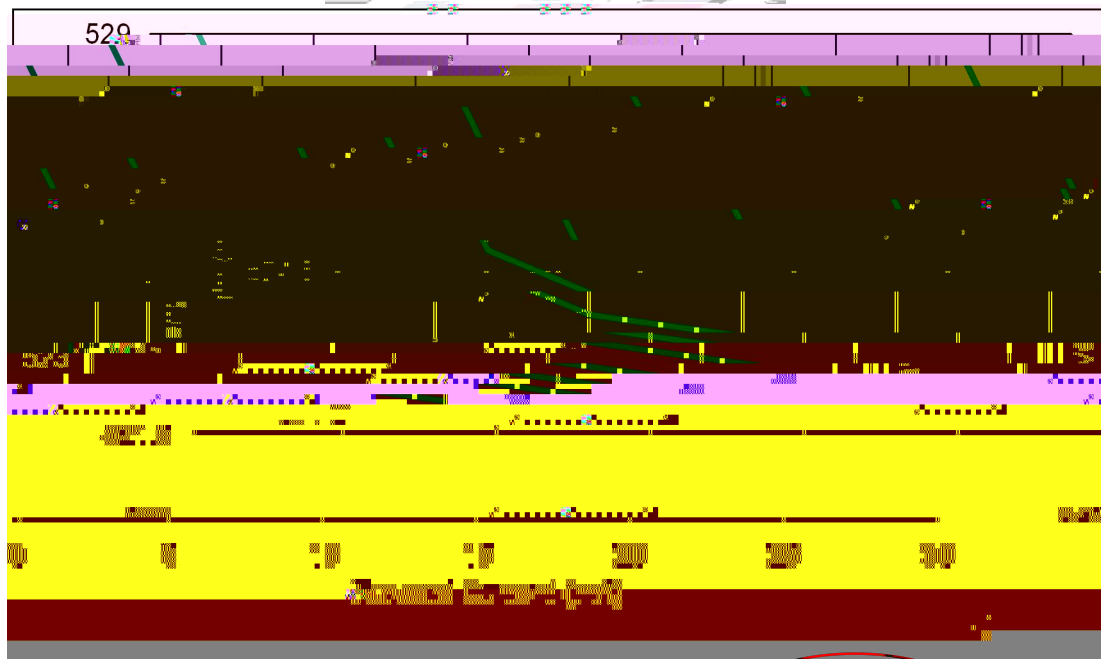
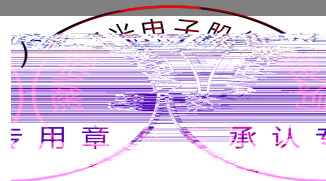

Fig.1-11 Forward Current Vs Dominate Wavelength (Ta=25)



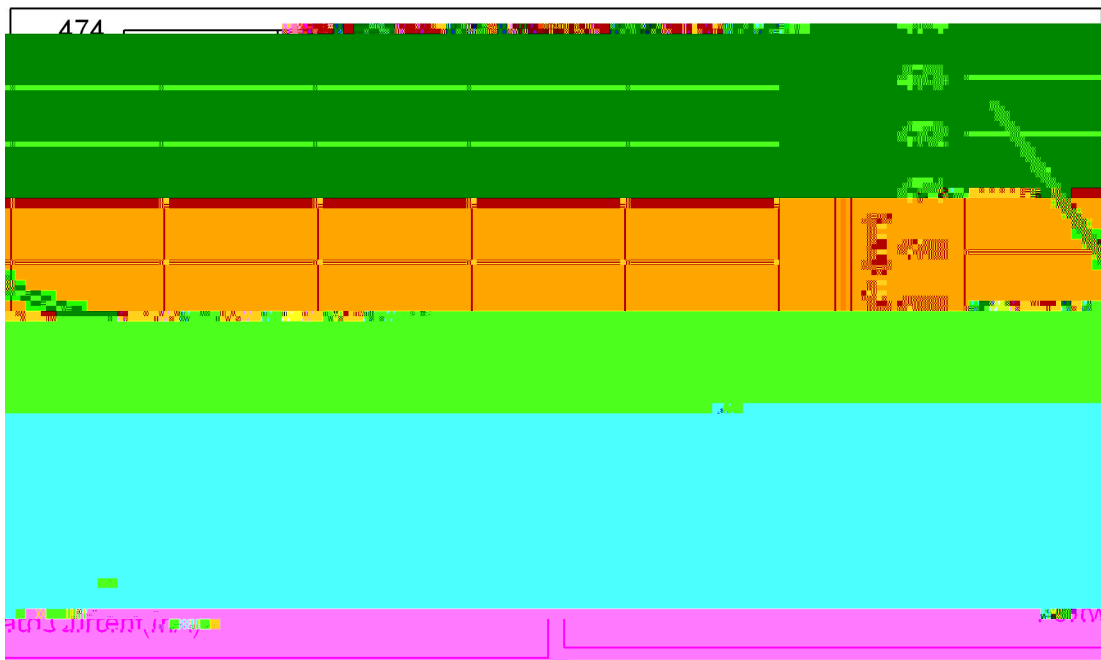

Fig.1-12 Forward Current Vs Dominate Wavelength (Ta=25)

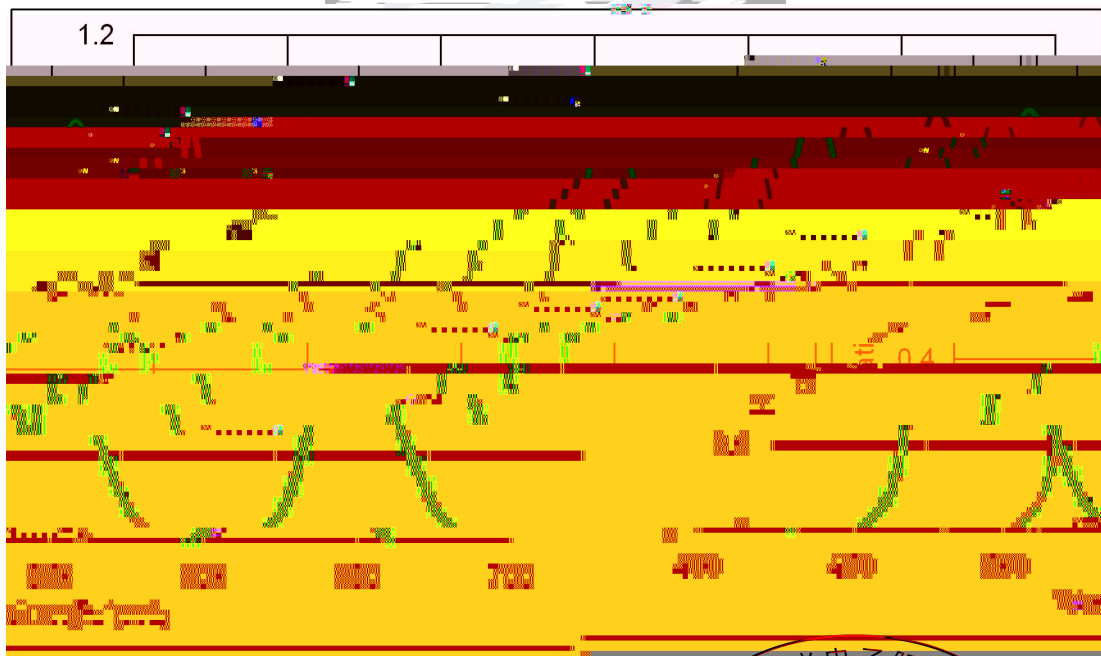
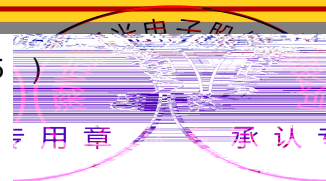

Fig.1-13 Relative Intensity Vs Wavelength (Ta=25)



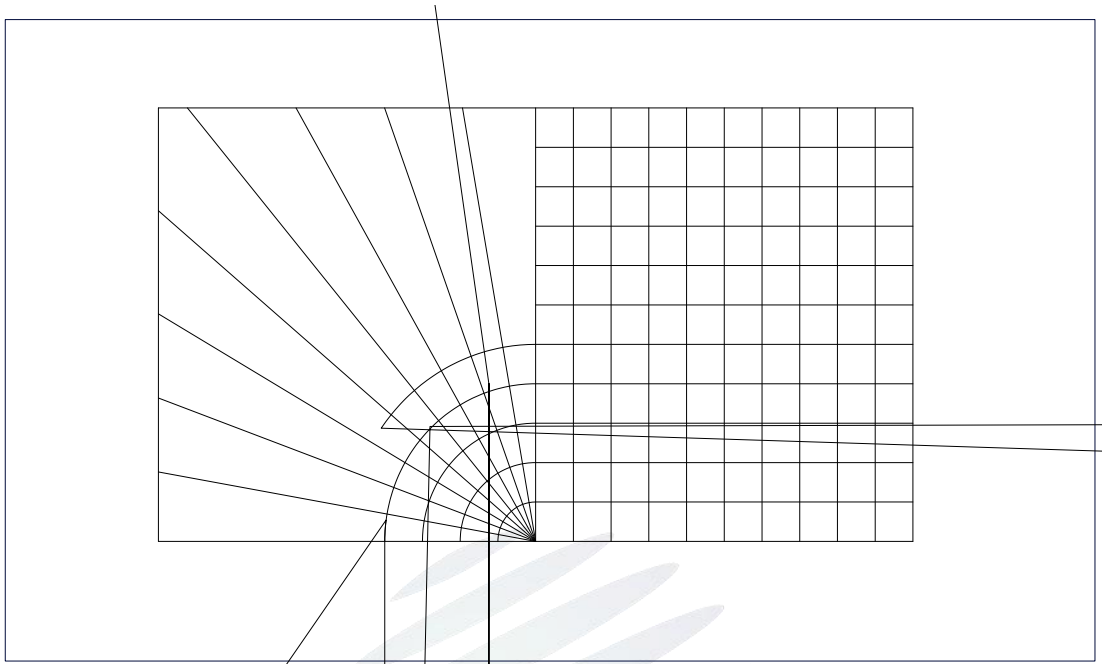
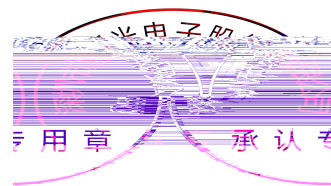
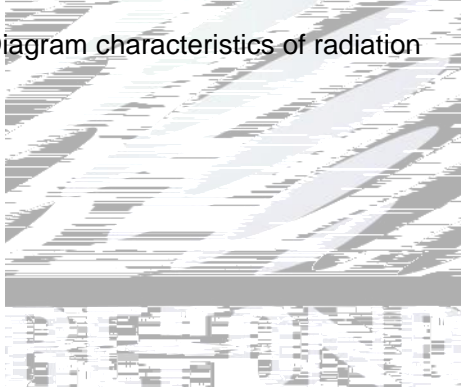
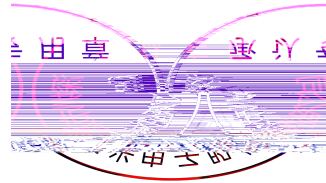

Fig.1-14 Diagram characteristics of radiation





Package:3000pcs/reel.

3000pcs

2.1.1 Carrier Tape Dimension



Fig.2-1 Carrier Tape Dimension

2.1.2 Reel Dimension

Ta

2.1.3 Label Form Specification

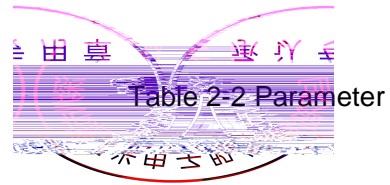

Fig. 2-3 Label Form Specification



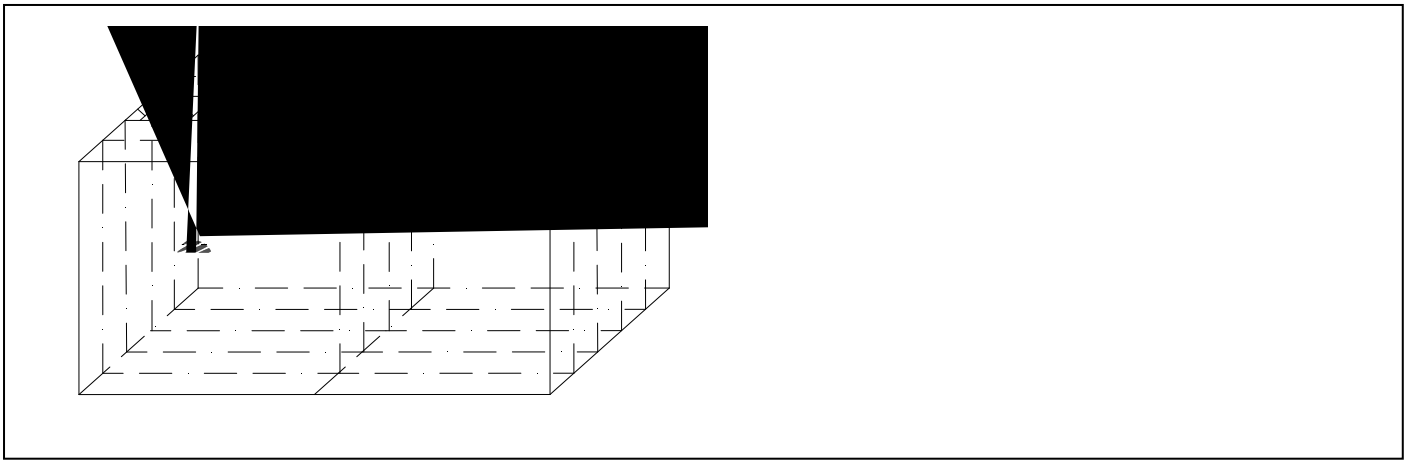

Fig.2-5 Cardboard Box

Table 2-3 Reliability Test Items And Conditions

Test Items	Ref.Standard	Test Condition	Time	Quantity	Ac/Re /
Reflow	JESD22-B106	Temp:260 max T=10 sec	2 times	22Pcs.	0/1
Temperature Cycle	JESD22-A104	100 30 min 5 min -40 30 min	100 cycles	22Pcs.	0/1
Thermal Shock	JESD22-A106	-40 15min 100 15min	300 cycles	22Pcs.	0/1
High Temperature Storage	JESD22-A103	Temp:100	1000 hrs.	22Pcs.	0/1
Low Temperature Storage	JESD22-A119	Temp:-40	1000 hrs.	22Pcs.	0/1
Life Test	JESD22-A108	T _a =25 I _F =20mA	1000 hrs.	22Pcs.	0/1

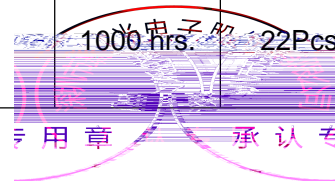
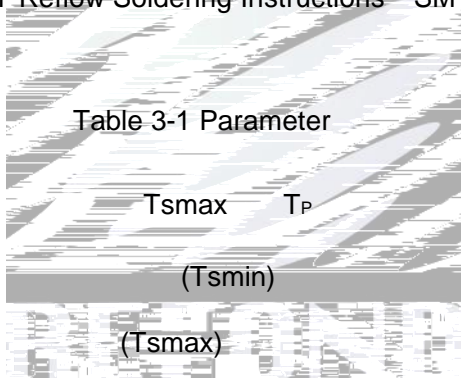

Table 2-4 Criteria For Judging Damage



Fig.3-1 SMT Reflow Soldering Instructions SMT



Parameter	Symbol	Value
Average temperature rise speed	T_{sm} / T_{sp}	3 °C/ s Max 3 °C/ s
Preheating: minimum temperature	(T_{smin})	150 °C
Preheating: Max temperature	(T_{smax})	200 °C
Preheating: Time	T_{smin} T_{smax}	60 - 120 60s-120s
Time limited to maintain high temperature: the temperature	(T_L)	217 °C
Time limited to maintain high temperature: The Time	(t_L)	60 - 150 60s-150s
Peak /Classification of temperature:	/ (T_P)	260 °C
Time limit classification of peak temperature time	t_p	10 Max 10s
Hold time within 5 °C with the actual peak temperature (T_P)	(T_P)	

Notes

(1)Re R

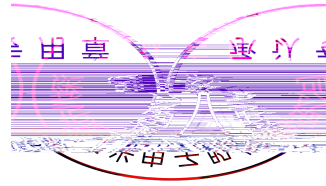

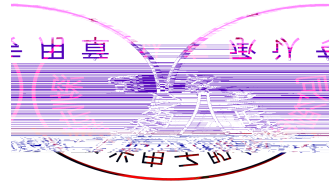

Electronics

(4) In designing a circuit, the current through each LED must be limited to the absolute maximum current specified for each LED. Otherwise, the LED will be damaged. The current through the LED must be limited to the absolute maximum current specified for each LED. Otherwise, the LED will be damaged. The current through the LED must be limited to the absolute maximum current specified for each LED. Otherwise, the LED will be damaged.

(5) Thermal Design is paramount importance because heat generation may result in the LED Characteristics decline, such as brightness decreased, Color change and so on. Please consider the heat generation of the LEDs when making the system design. LED

(6) Storage

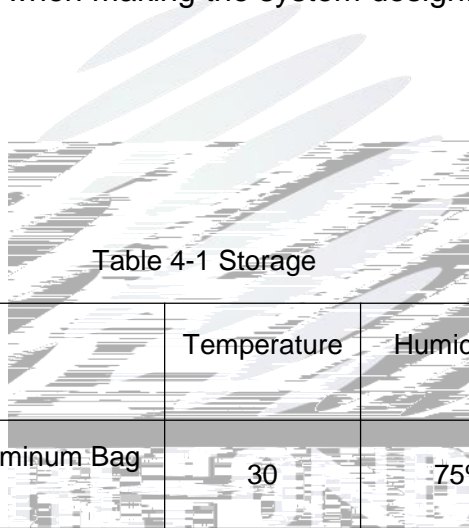

Table 4-1 Storage

Conditions		Temperature	Humidity	Time
Storage	Before Opening Aluminum Bag	30	75%	Within 1 Year From Date
	After Opening Aluminum Bag	30	60%	168hours 168
Baking		60 ± 5	-	24hours 24

(7) If the moisture absorbent material silica gel has faded away or the LEDs have exceeded the storage time baking treatment should be performed after unpacking and based on the following condition 60±5 for above 24 hours.

If the package is flatulence

(8) Similar to most Solid state devices; LEDs are sensitive to Electro-Static Discharge (ESD) and Electrical Over Stress (EOS).

(9) Other points for attention, please refer to our relevant information.

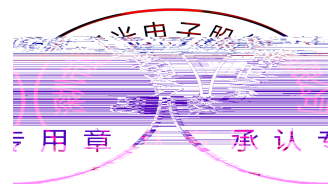



Declare

This specification is written both in English and in Chinese and the latter is formal.

