

# SPECIFICATION

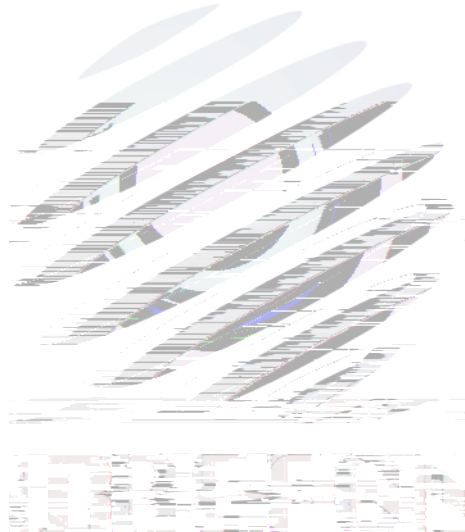

## Contents

1. Description	3
1.1 General Description	3
1.2 Features	



## 1. Description

### 1.1

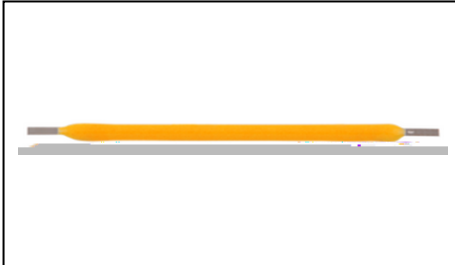

The White LED, which was fabricated by using a blue chip and the phosphor.

Product Package:40.0mm×1.5mm×2.2mm.

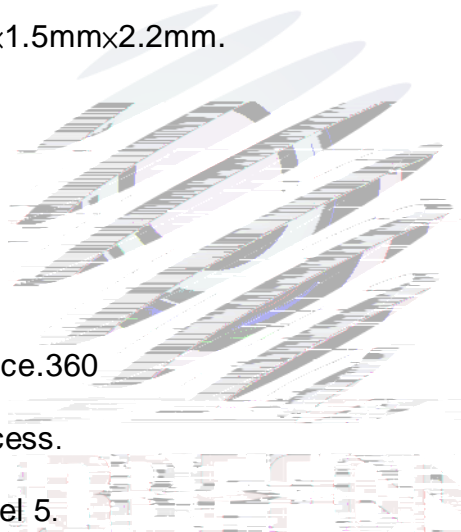

40.0mm×1.5mm×2.2mm

### 1.2 Features

Integrated Package.

360 ° Full Angle Luminescence.360

Suitable for spot welding process.

Moisture sensitivity level: Level 5.

RoHS compliant.

### 1.3 Application

Indoor lighting.

Decorative applications.

General use.

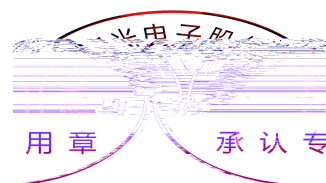

### 1.4 Package Dimension

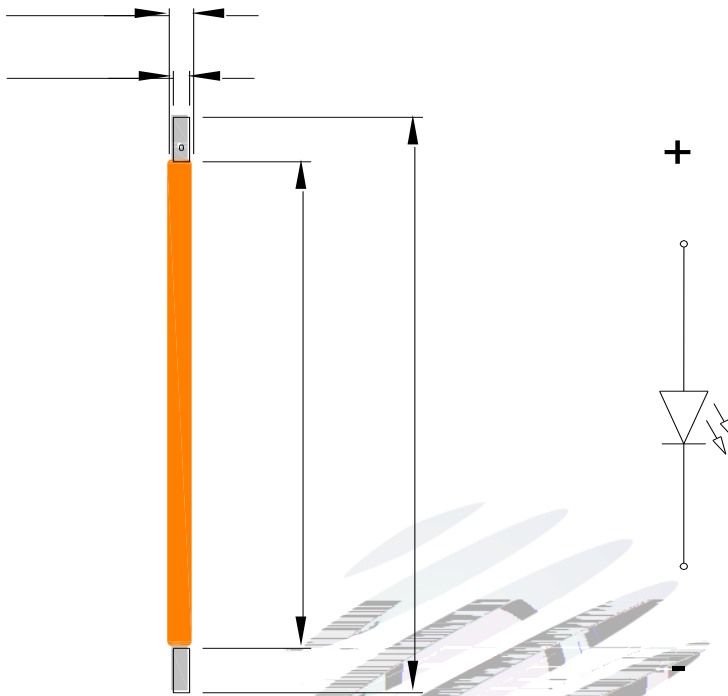

Fig.1-1 Top View

Fig.1-2 Side View

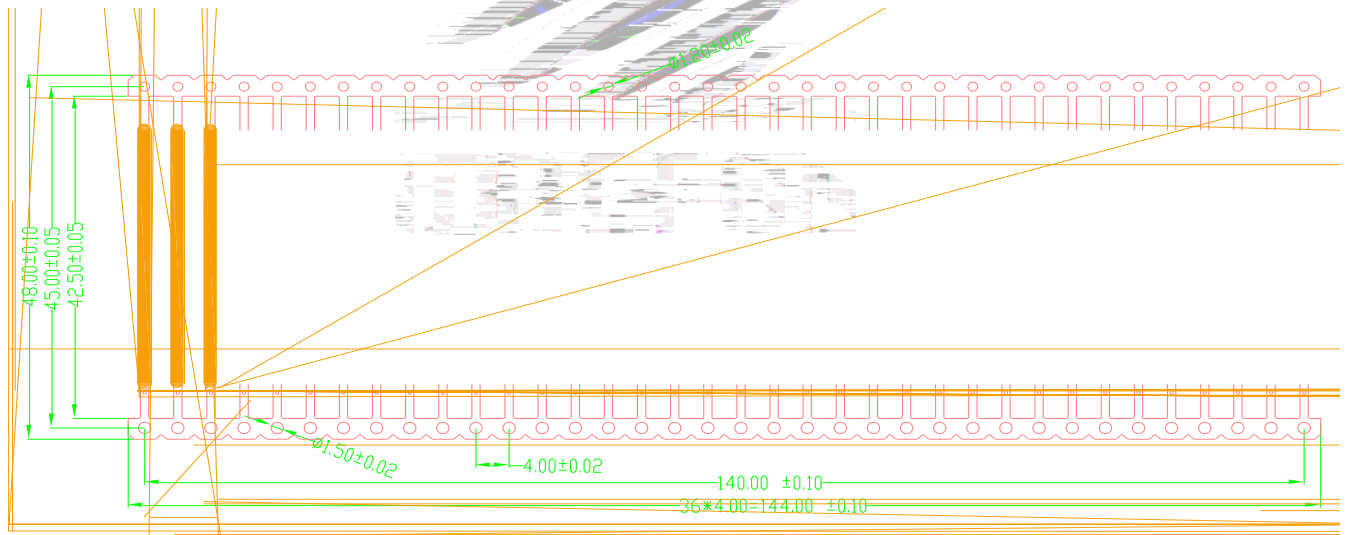
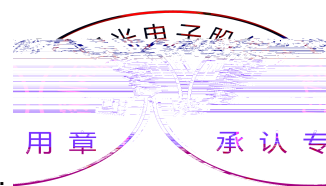

Fig.1-3 Whole Line View

Notes

All dimensions units are millimeters.

All dimensions tolerances are  $\pm 0.10$  mm unless otherwise noted.



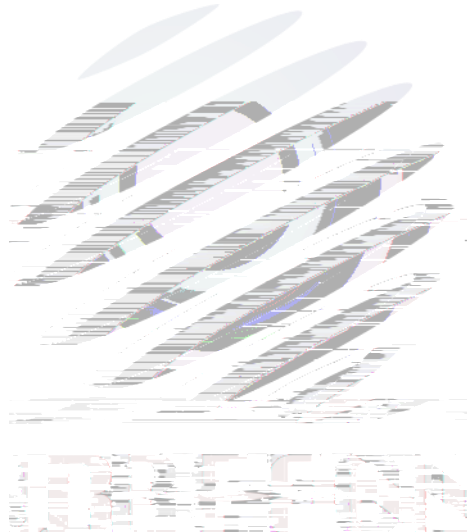

Notes



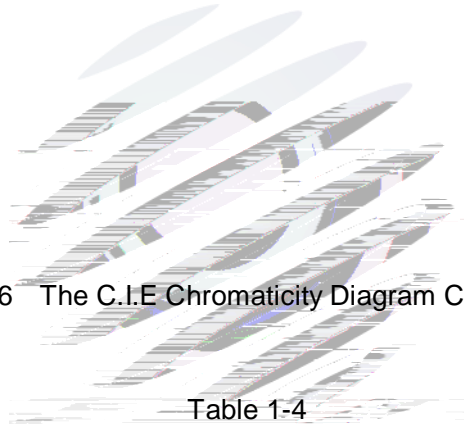

Fig. 1-6 The C.I.E Chromaticity Diagram CIE

Table 1-4

BIN CODE	CIE-X1	CIE-Y1	CIE-X2	CIE-Y2	CIE-X3	CIE-Y3
----------	--------	--------	--------	--------	--------	--------

### 1.7 Typical Optical Characteristics Curves

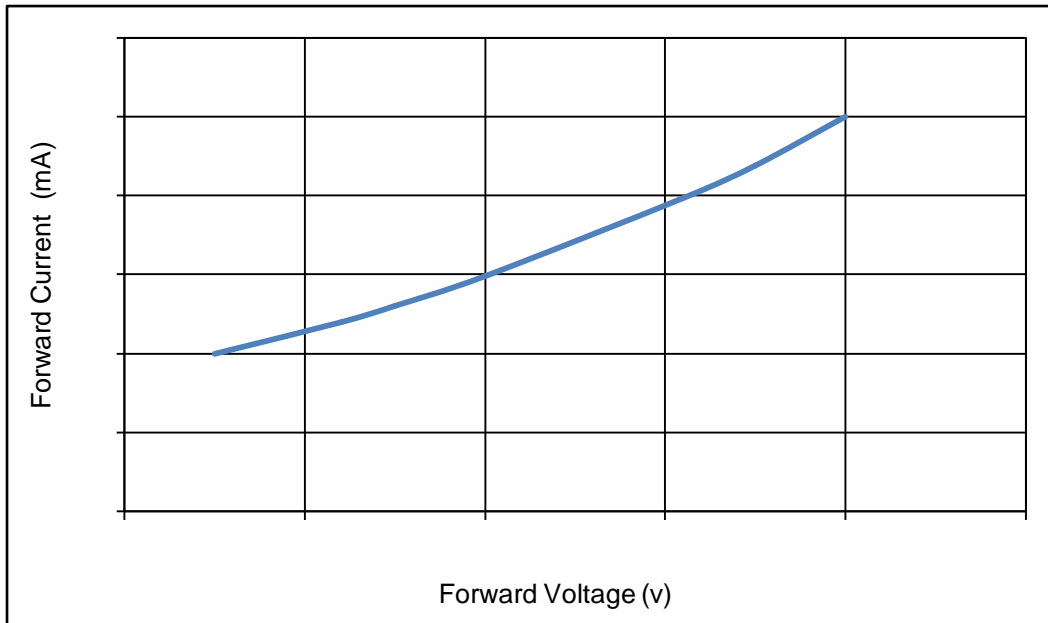

Fig. 1-7 Forward Voltage Vs Forward Current

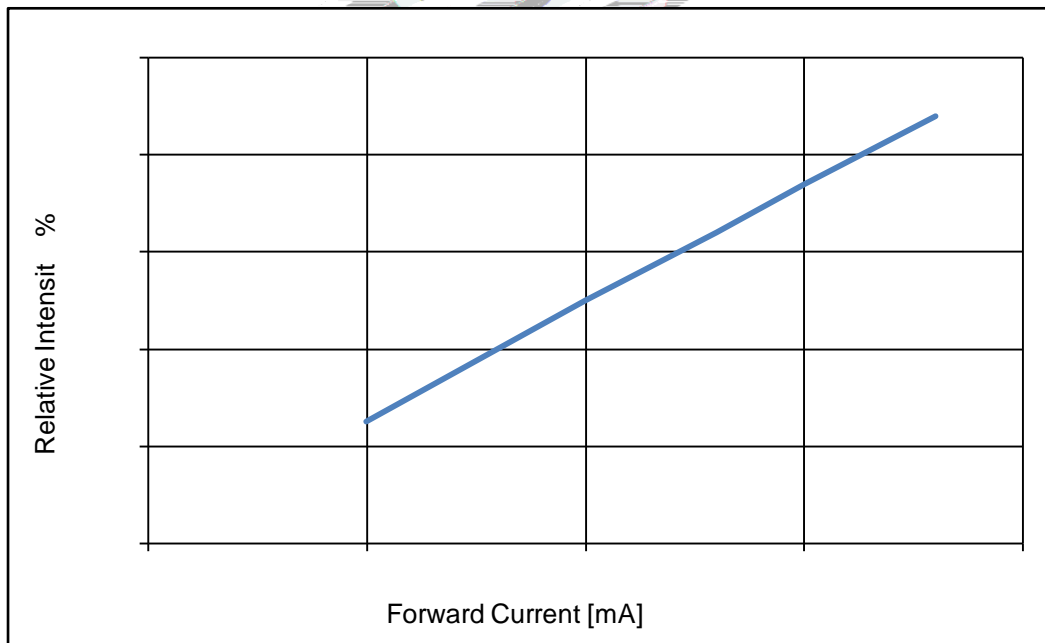
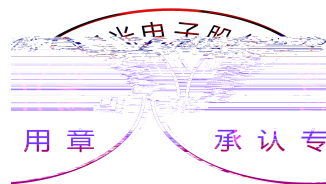
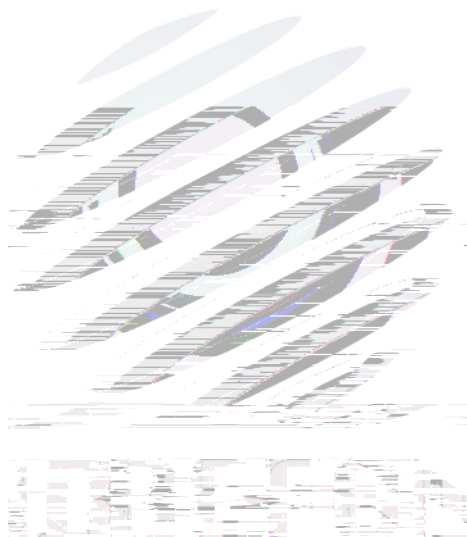

Fig. 1-8 Forward Current Vs Relative Intensity







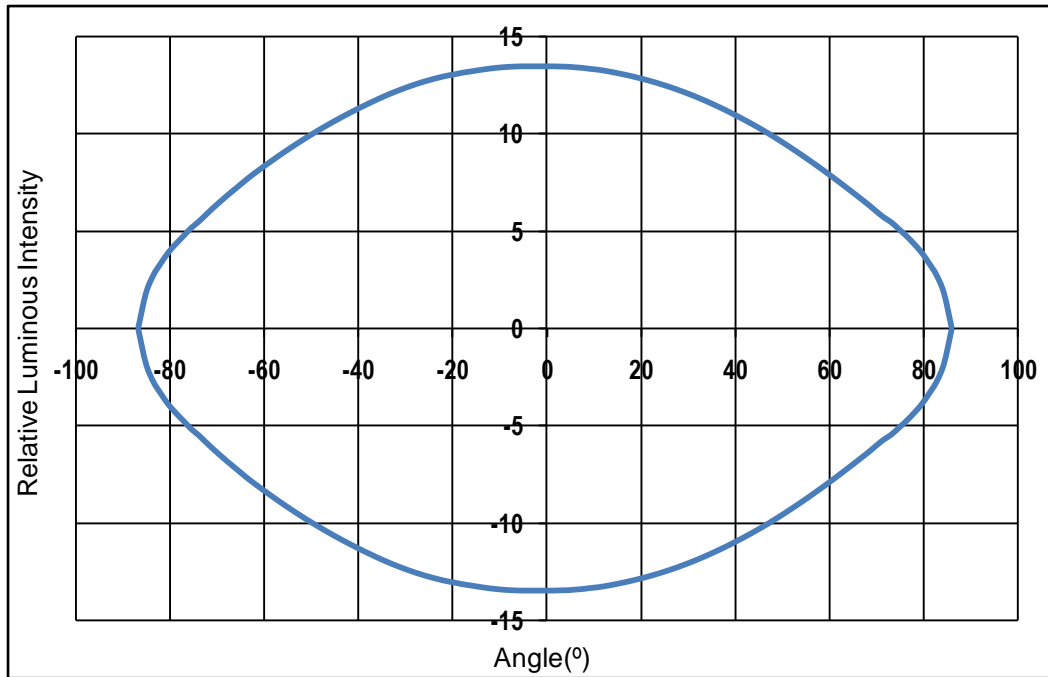

Fig. 1-11 Radiation diagram

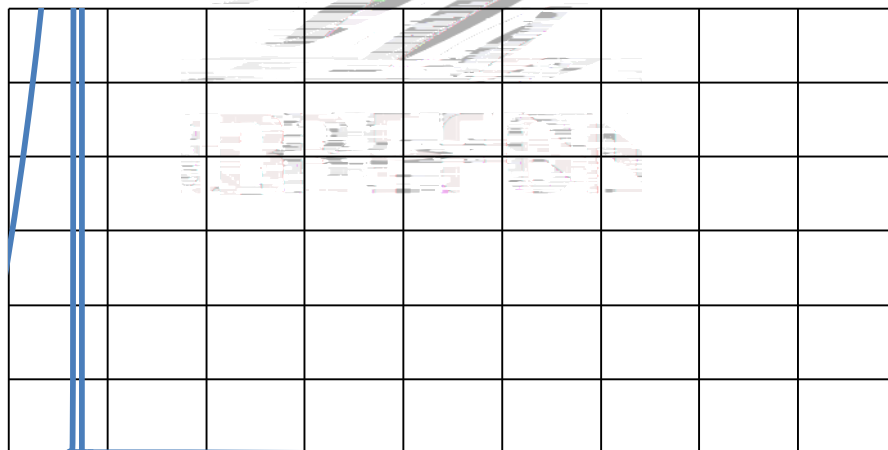
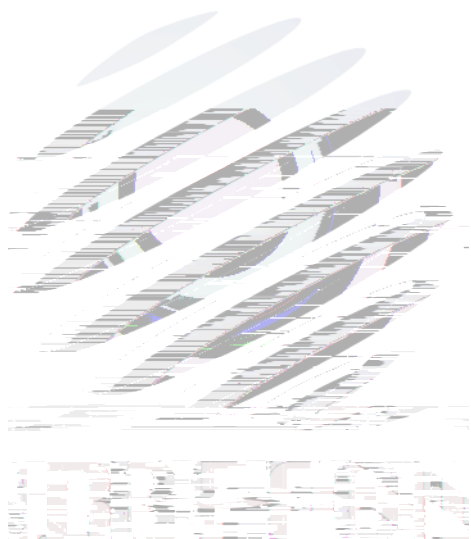
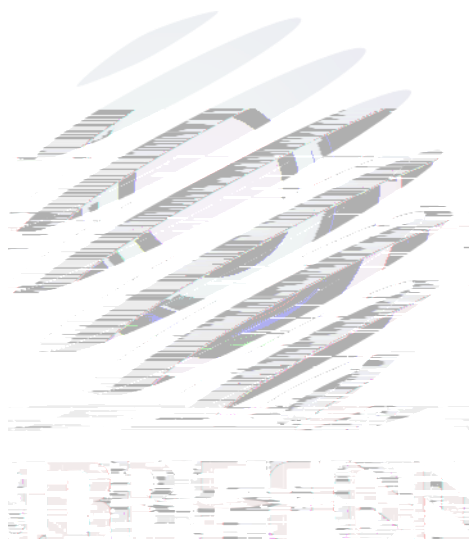

Fig. 1-12 Spectrum Distribution





## 2.3 Cardboard Box

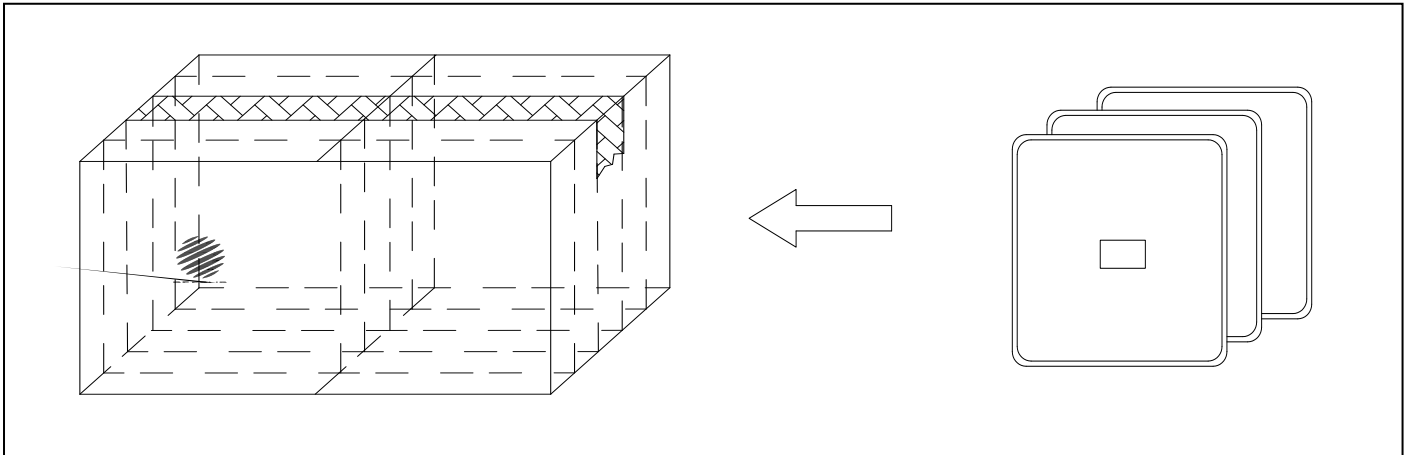

Fig.2-4 Cardboard Box

## 2.4 Reliability Test Items And Conditions

Table 2-2 Reliability Test Items And Conditions

Test Items	Ref.Standard	Test Condition	Time	Quantity	Ac/Re /
Thermal Shock	JEITAED-4701 300307	-40 15min 10s 100 15min	100 cycle	20pcs	0/1
Switching Test	/	25 , On 2.5min Off 2.5min	2500cycle	20pcs	0/1
Life Test	JESD22-A108	Ta=25 If=13mA	1000hrs	10pcs	0/1
High Temperature High Humidity Life Test	JESD22-A101	60 / 90%RH If=13mA	500hrs	10pcs	0/1

用章 承认专

## 2.5 Criteria For Judging Damage

Table 2-3 Criteria For Judging Damage

Test Items	Symbol	Test Condition	Criteria For Judgement	
			Min.	Max.
Forward Voltage	$V_F$	$I_F=13mA$	-	Forward Voltage
Luminous Flux		$I_F=13mA$	L.S.L*)x0.7	Luminous Flux

### Notes

- 1.U.S.L: Upper standard level      L.S.L: Lower standard level
2. The above reliability tests is based on the verification of a single/strip LED of Refond's existing experimental platform, the reliability experiment was taken under good heat dissipation conditions. when customers applies the LED to the series and parallel circuit, should take consideration of all the factors such as the current, voltage distribution, heat dissipation and others.
- 3.The technical information shown in the data sheets is limited to the typical characteristics and circuit examples of the referenced products. It does not constitute the warranting of industrial property nor the granting of any license.

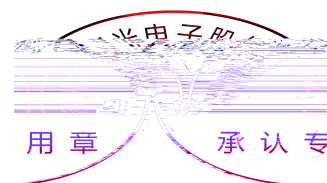

### 3. Handling Precautions

(1) LED operating environment and sulfur element composition cannot be over 100PPM in the LED mating usage material. This is provided for informational purposes only and is not a warranty or endorsement. LED

(2) In order to prevent external material from getting into the inside of LED, which may cause the malfunction of LED, the single content of Bromine element is required to be less than

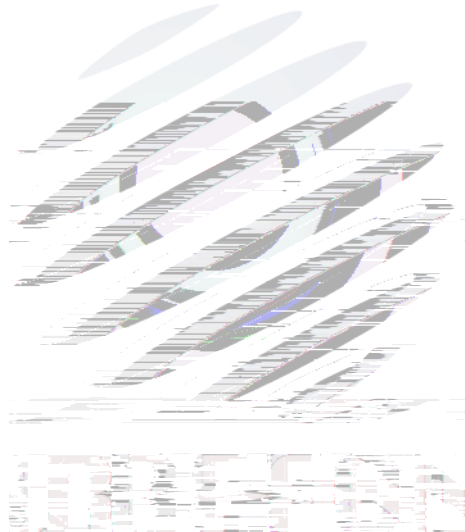

(4) Handle the component along the side surface by using forceps or appropriate tools; Do not directly touch or Handle the silicone lens surface, it may damage the internal circuitry.



(5) In designing a circuit, the current through each LED can not exceed the absolute maximum rating specified for each LED. In the meanwhile, resistors for protection should be applied, otherwise slight voltage shift will cause big current change, burn out may happen. The driving circuit must be designed to allow forward voltage only when it is ON or OFF. If the reverse voltage is applied to LED, migration can be generated resulting in LED damage.

(6) Thermal Design is paramount importance because heat generation may result in the Characteristics decline, such as brightness decreased, Color change and so on. Please consider the heat generation of the LEDs when making the system design. LED

(7) Compared to standard encapsulants, silicone is generally softer, and the surface is more likely to attract dust, requiring special care during processing. In cases where a minimal level of dirt and dust particles cannot be guaranteed, a suitable cleaning solution must be applied to the surface after the soldering of components. Refond suggests using isopropyl alcohol for cleaning. In case other solvents are used, it must be assured that these solvents do not dissolve the package or resin. Ultrasonic cleaning is not recommended. Ultrasonic cleaning may cause damage to the LED.



Table 4-1Storage

Conditions	Temperature	Humidity	Time
Before Opening Aluminum Bag	30	75%	Within 1 Year From Date

After Opening Aluminum Bag

30

60%

24hours

24

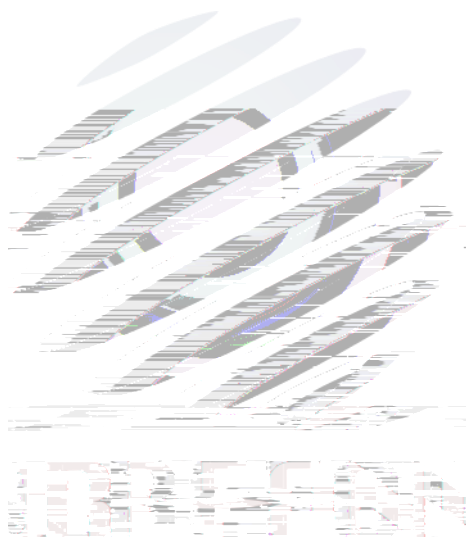





Declare

This specification is written both in English and in Chinese and the latter is formal.

