

# SPECIFICATION 产品规格书

REFOND P/N 产品型号

RF-AL-E3030L2K0FR-02

R&D 研发

Mass Product 量产供货

## Contents 目錄

|   |    |
|---|----|
| 1. Description 产品介绍.....                                  | 3  |
| 1.1 General Description 产品描述.....                         | 3  |
| 1.2 Features 产品特征.....                                    | 3  |
| 1.3 Application 产品应用.....                                 | 3  |
| 1.4 Package Dimension 封装尺寸.....                           | 4  |
| 1.5 Product Parameters 产品参数.....                          | 5  |
| 1.6 Typical optical characteristics curves 典型光学特性曲线.....  | 7  |
| 2. Packaging 产品包装.....                                    | 10 |
| 2.1 Packaging Specification 包装规格.....                     | 10 |
| 2.1.1 Carrier Tape Dimension 载带尺寸.....                    | 10 |
| 2.1.2 Reel Dimension 卷盘尺寸.....                            | 10 |
| 2.1.3 Label Form Specification 标签规格.....                  | 11 |
| 2.3 Cardboard Box 包装纸箱.....                               | 11 |
| 2.4 Reliability Test Items And Conditions 信赖性测试项目及条件..... | 12 |
| 2.5 Criteria For Judging Damage 失效判定标准.....               | 13 |
| 3. SMT Reflow Soldering Instructions SMT 回流焊说明.....       | 14 |
| 3.1 SMT Reflow Soldering Instructions SMT 回流焊说明.....      | 14 |
| 4. Handling Precautions 产品使用注意事项.....                     | 16 |
| 4.1 Handling Precautions 产品使用注意事项.....                    | 16 |

## 1. Description 产品介绍

### 1.1 General Description 产品描述



This product uses the EMC Molding package, it has a high reliability. it also be widely application for Grow Lamps, such as flower production, tissue culture, plant factory, greenhouse and refreshment.

Size(mm): 3.00mmX3.00mmX3.08mm.

本产品采用EMC Molding封装结构，可靠性高。广泛应用于各种植物光照应用中，例如：花卉生产、组织培养，植物工厂，温室蔬菜与水果，冰箱保鲜。

产品尺寸：3.00mmX3.00mmX3.08mm.

### 1.2 Features 产品特征

Size(mm): 3.00x3.00x3.08mm. 尺寸(mm): 3.00x3.00x3.08mm

730nm. 峰值波长 730nm

Pb-free reflow soldering application. 无铅回流焊应用

Package:2500pcs/reel. 包装:每卷2500pcs

Moisture sensitive level:Level3. 防潮等级: Level 3

RoHS compliant. 符合RoHS

### 1.3 Application 产品应用

Flower production.

Tissue culture.

Plant factory.

Refreshment.

## 1.4 Package Dimension 封装尺寸

Fig.1-



## 1.5 Product Parameters 产品参数

Table 1-1 Electrical / Optical Characteristics at Ts=25°C 电性与光学特性

| Item<br>项目                  | Symbol<br>符号 | Test Condition<br>测试条件 | Value         |              |               | Unit<br>单位  |
|-----------------------------|--------------|------------------------|---------------|--------------|---------------|-------------|
|                             |              |                        | Min.<br>(最小值) | Typ<br>(典型值) | Max.<br>(最大值) |             |
| Reverse Current<br>(漏电流)    | $I_R$        | $V_R=5V$               | ---           | ---          | 10            | $\mu A$     |
| Forward Voltage<br>(正向电压)   | $V_F$        | $I_F=350mA$            | 1.8           | ---          | 2.6           | V           |
| Peak Wavelength<br>(峰值波长)   | $\lambda_p$  | $I_F=350mA$            | 730           | ---          | 740           | nm          |
| Total radiant flux<br>辐射功率  | $\Phi_e$     | $I_F=350mA$            | 180           | ---          | 480           | mW          |
| Viewing Angle<br>(发光角度)     | 4            | $I_F=350mA$            | ---           | 30           | ---           | deg         |
| Thermal Resistance.<br>(热阻) | $R_{THJ-S}$  | $I_F=350mA$            | ---           | 14           | ---           | $^{\circ}W$ |

Table 1-2 Absolute Maximum Ratings at Ts=25°C 绝对最大值

| Parameter (参数)         | Symbol (符号) | Rating (值) | Units (单位) |
|------------------------|-------------|------------|------------|
| Power Dissipation (功耗) | $P_D$       | 1.3        | W          |

## Notes 备注:

- 1.1/10 Duty cycle, 0.1ms pulse width. 脉宽0.1ms,占空比1/10.
- 2.The above forward voltage measurement allowance tolerance is  $\pm 0.1V$ . 以上所示电压测量误差  $\pm 0.1V$ .
3. The above wavelength measurement allowance tolerance is  $\pm 1nm$ . 以上所示波长测量误差  $\pm 1nm$ .
4. Tolerance of measurement of Total radiant flux/ Radiant Intensity:  $\pm 10\%$ . 辐射功率/强度测量公差:  $\pm 10\%$ .
5. Care is to be taken that power dissipation does not exceed the absolute maximum rating of the product. 使用功率不能超过规定的最大值。
6. All measurements were made under the standardized environment of Refond. 的所有测试都是基于瑞丰现有标准测试平台。
- 7.When the LEDs are in operation the maximum current should be decided after measuring the package temperature, junction temperature should not exceed the maximum rate. LED 使用的最大电流需要根据散热条件确定, 结温不能超过最大值。

## 1.6 Typical optical characteristics curves 典型光学特性曲线

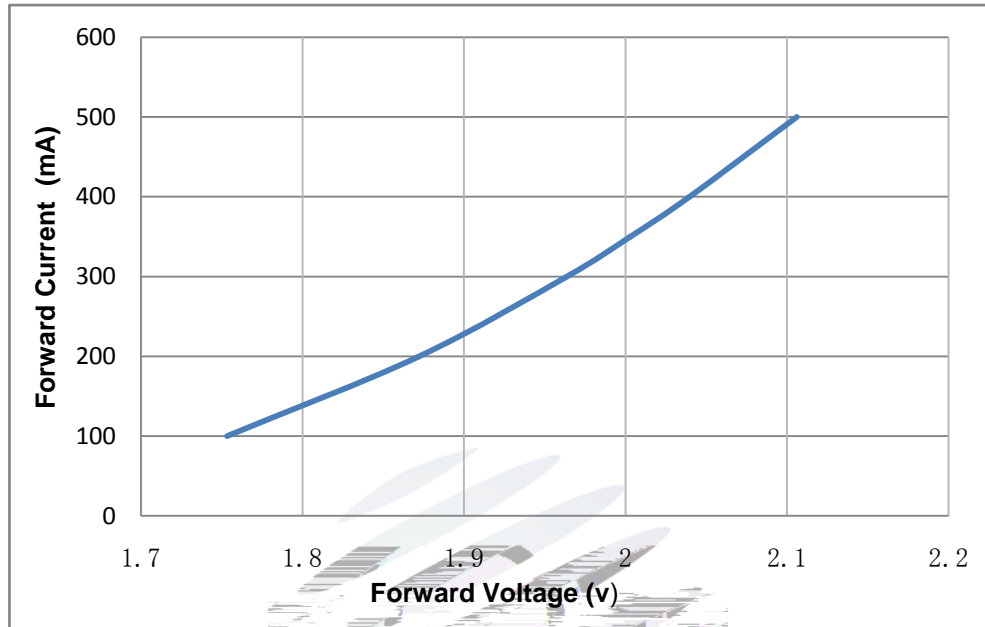

Fig 1-6 Forward Voltage Vs. Forward Current伏安特性曲线

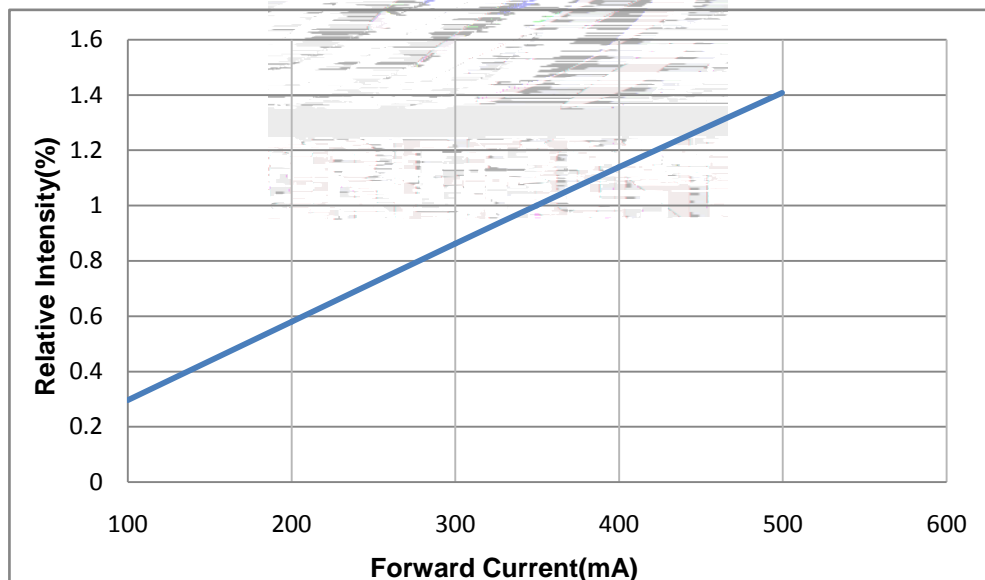

Fig 1-7 Forward Current Vs. Relative Intensity正向电流与相对光强特性曲线

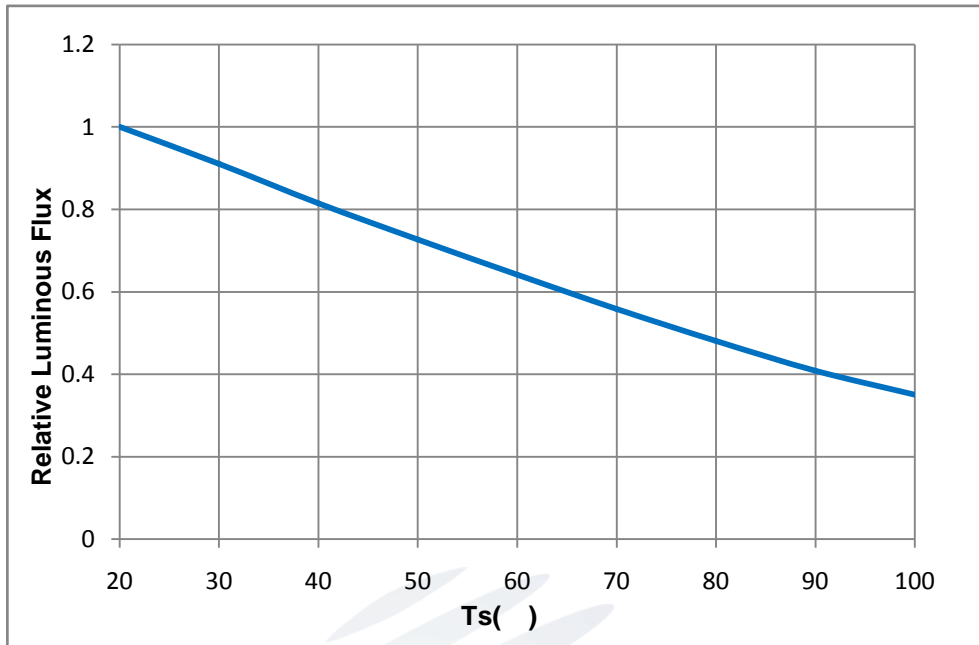

Fig 1-8 Ts Temperature Vs Relative Intensity 管脚温度与相对光强特性曲线

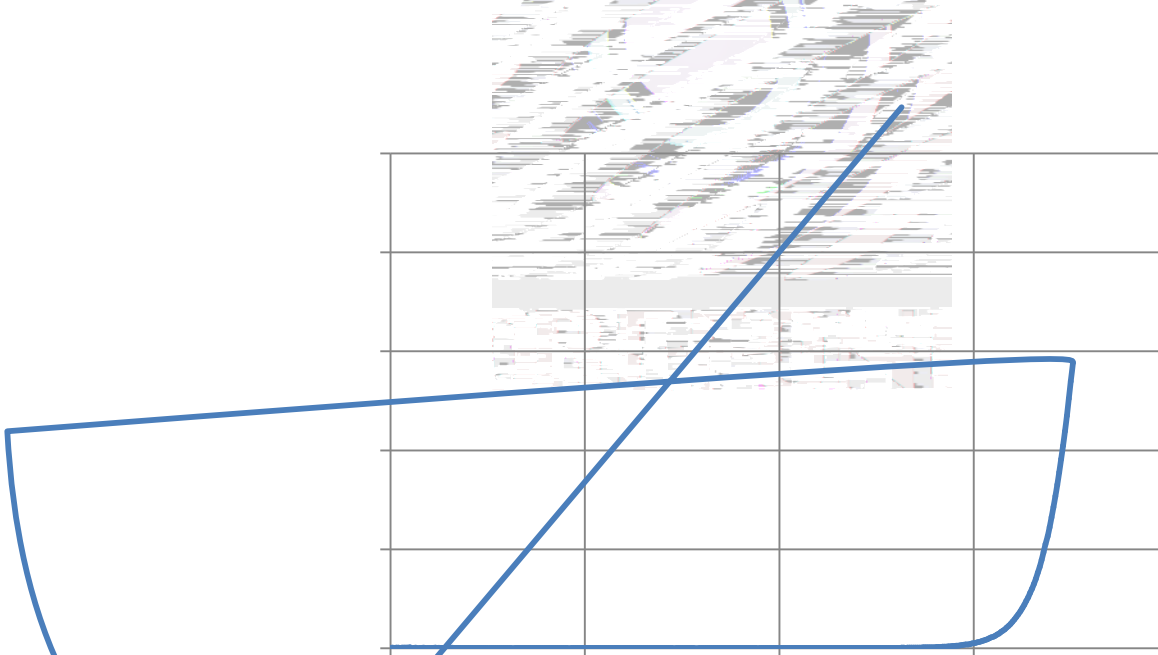

Fig 1-9 Spectrum Distribution 光谱分布特性曲线



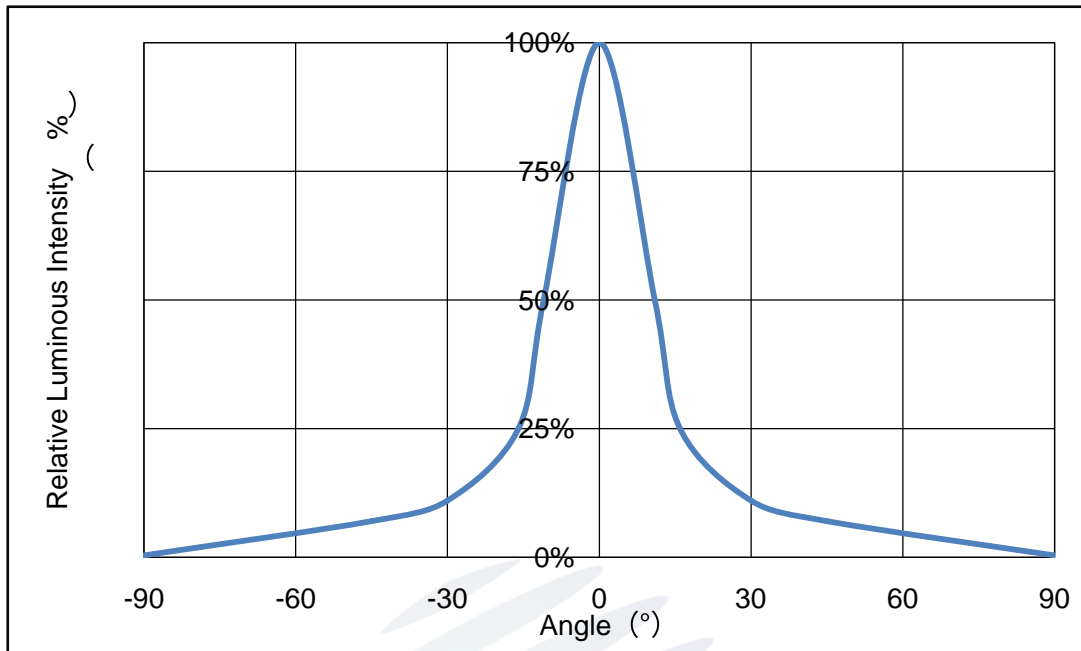

Fig 1-10 Radiation diagram 辐射特性曲线

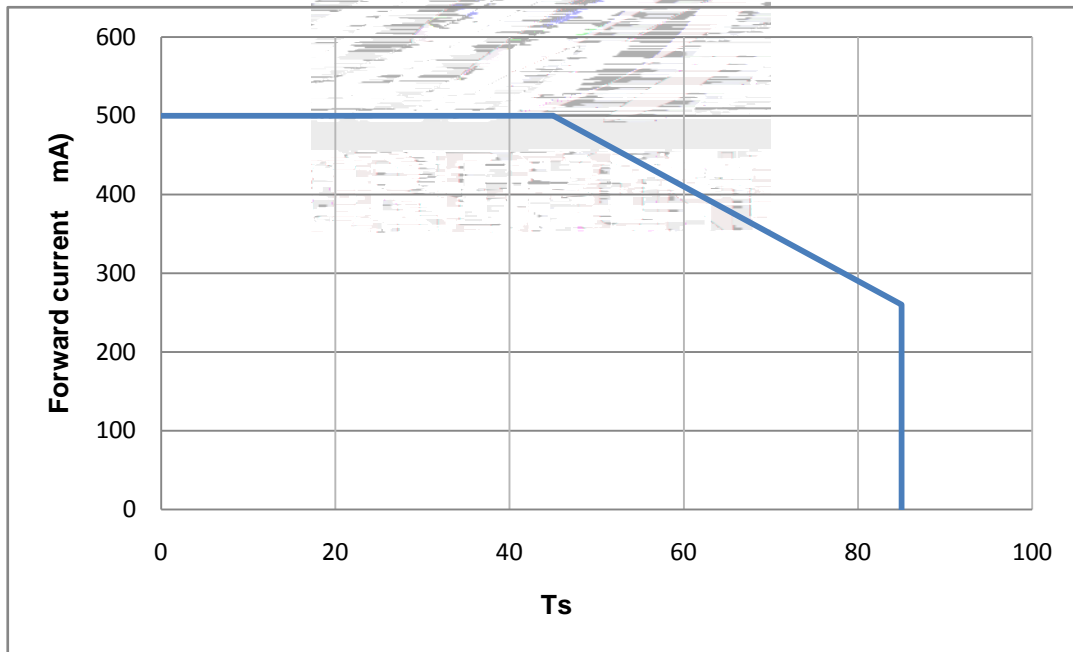

Fig 1-11 Ts Temperature Vs Forward Current 管脚温度与正向电流特性曲线

## 2. Packaging 产品包装

### 2.1 Packaging Specification 包装规格

Package:2500pcs/reel.包装每卷 2500pcs。

#### 2.1.1 Carrier Tape Dimension 载带尺寸

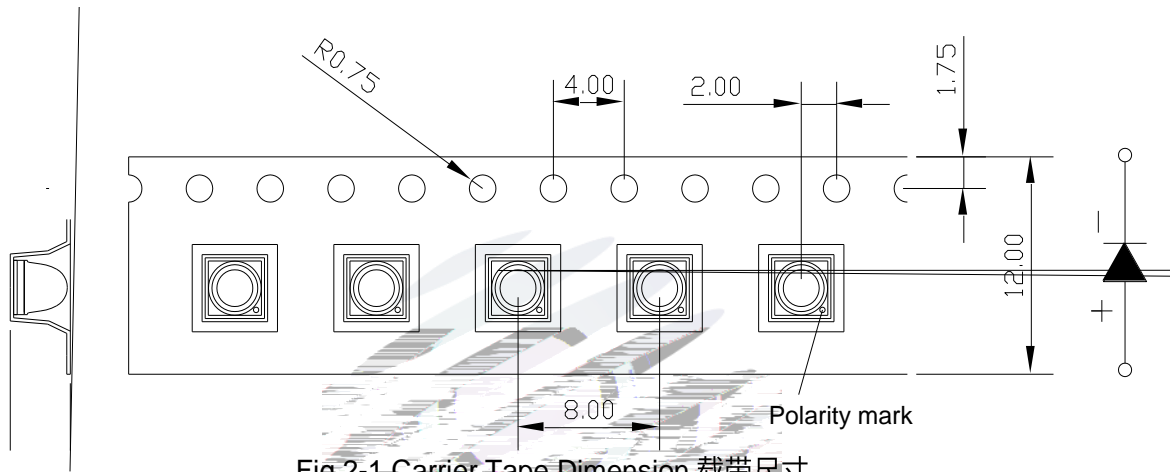

Fig.2-1 Carrier-Tape Dimension 载带尺寸

#### 2.1.2 Reel Dimension 卷盘尺寸

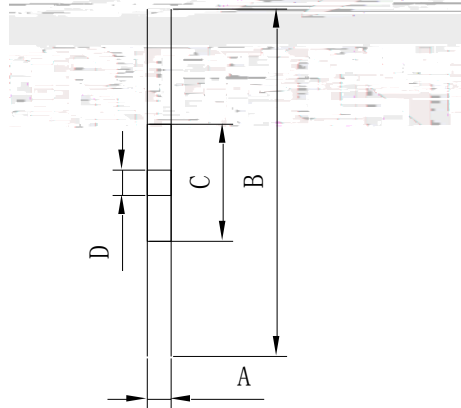
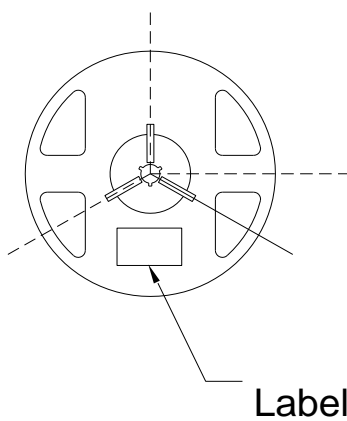

Table 2-1 Dimension 尺寸

|   |            |
|---|------------|
| A | 12.7±0.3mm |
| B | 330.2±2mm  |
| C | 79.5±1mm   |
| D | 14.3±0.2mm |

Fig.2-2 Reel Dimension 卷盘

Notes 备注:

The tolerances unless mentioned ± 0.1mm. Unit : mm 注：未注公差为± 0.1毫米，尺寸单位：毫米。

### 2.1.3 Label Form Specification 标签规格

Table 2-2 Label Form Specification 标签规格

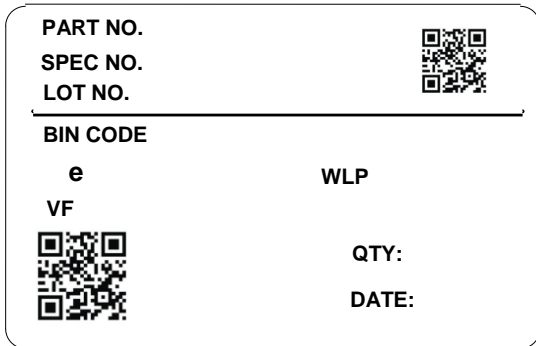

|          |                        |
|----------|------------------------|
| PART NO  | Part Number 品名         |
| SPEC NO  | Spec Number 规格         |
| LOT NO   | Lot Number 批次号         |
| BIN CODE | Bin Code 色区            |
|          | Total radiant flu 辐射功率 |
| WLP      | Peak Wavelength 峰值波长   |
| VF       | Forward Voltage 正向电压   |
| QTY      | Packing Quantity 数量    |
| DATE     | Made Date 生产日期         |

Fig 2-3 Label Form Specification 标签规格

### 2.2 Moisture Resistant Packing 防潮包装



Fig.2-4 Moisture Resistant Packing 防潮包装

### 2.3 Cardboard Box 包装纸箱

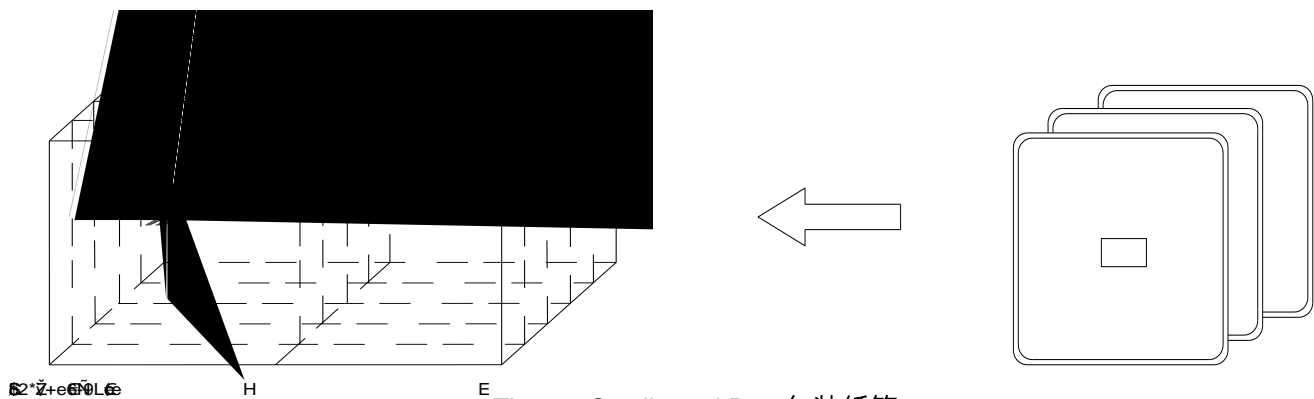

Fig.2-5 Cardboard Box 包装纸箱



## 2.5 Criteria For Judging Damage 失效判定标准

Table Criteria For Judging Damage 失效判定标准

| Test Items<br>项目        | Symbol<br>符号 | Test Condition<br>测试条件 | Criteria For Judgement<br>判定标准 |                      |
|-------------------------|--------------|------------------------|--------------------------------|----------------------|
|                         |              |                        | Min. 最小                        | Max. 最大              |
| Forward Voltage<br>正向电压 | $V_F$        | $I_F=350\text{mA}$     | -                              | $U.S.L^*)\times 1.1$ |
| Reverse Current<br>反向电流 | $I_R$        | $V_R = 5V$             | -                              | $U.S.L^*)\times 2.0$ |

Total radiant flux

辐射功率

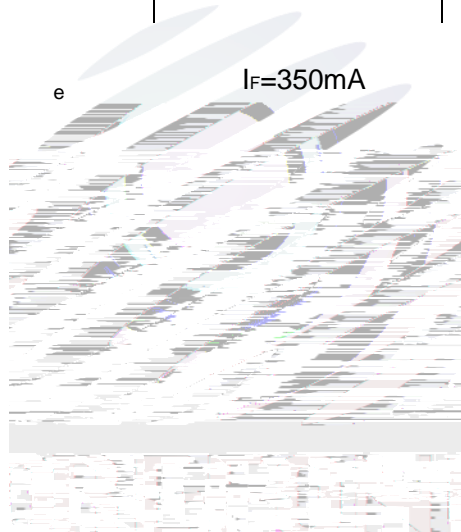

### 3. SMT Reflow Soldering Instructions SMT 回流焊说明

#### 3.1 SMT Reflow Soldering Instructions SMT 回流焊说明

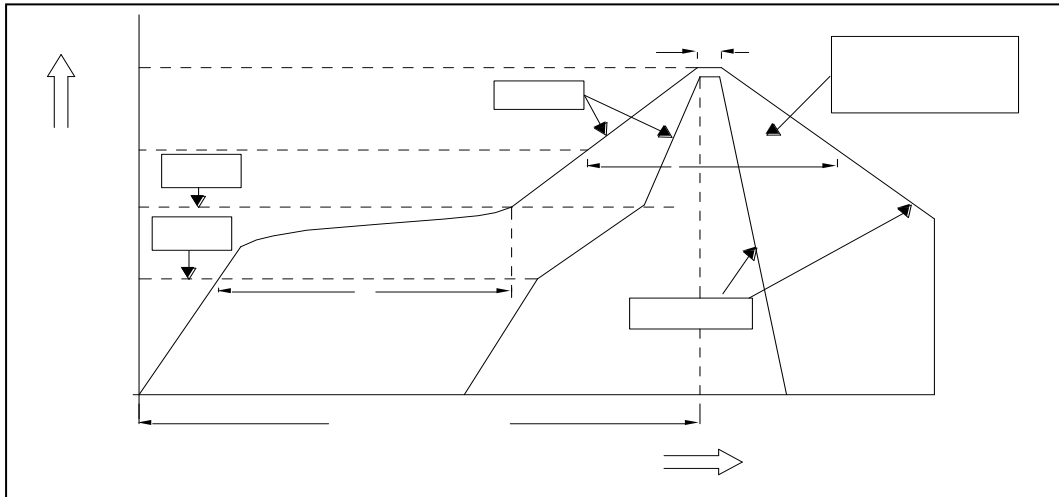

Fig.3-1 SMT Reflow Soldering Instructions SMT 回流焊说明

Table 3-1 Parameter 参数

|  |                      |
|--|----------------------|
| Average temperature rise speed 平均升温速度 (Tmax至Tp)  | 最高3 °C/秒 Max 3 °C/ s |
| Preheating: minimum temperature 预热: 最低温度 (Tmin)  | 150 °C               |
| Preheating: Max temperature 预热: 最高温度 (Tmax)  | 200 °C               |
| Preheating: Time 预热: 时间 (Tmin至Tmax)  | 60 - 120秒 60s-120s   |
| Time limited to maintain high temperature: the temperature : 温度(TL)                      | 217 °C               |
| Time limited to maintain high temperature: The Time 限时维持高温: 时间 (tL)                      | 最多60秒 Max 60s        |
| Peak /Classification of temperature: 峰值 / 分类温度 (Tp)                                      | 260 °C               |
| Time limit classification of peak temperature time 限时峰值分类温度: 时间 (tp)                     | 最多10秒 Max 10s        |
| Hold time within 5 °C with the actual peak temperature (TP) 与实际峰值温度 (Tp) 相差 5 °C 以内的保持时间 | 最多30秒 Max 30s        |
| Cooling speed 降温速度   | 最高6 °C/秒 Max 6 °C/ s |
| Needed time from 25 °C to Tp 25 °C 升至峰值温度所需时间  | 最多8分钟 Max 8 minutes  |

## Notes 备注:

(1) Reflow soldering should not be done more than two times. In the case of more than 24 hours passed soldering after first, LEDs will be damaged. 回流焊次数不可以超过两次，两次回流焊的时间间隔如果超过24小时，LED可能由于吸湿而损坏。

(2) When soldering, do not put stress on the LEDs during heating. 当焊接时，不要在材料受热时用力压胶体表面。

### 3.1.1 Soldering Iron 烙铁焊接

(1) When hand soldering, keep the temperature of iron below less 300°C less than 3 seconds

当手工焊接时，烙铁的温度必须低于300°C，时间不可超过3秒。

(2) The hand solder should be done only one time. 手工焊接只可焊接一次。

### 3.1.2 Repairing 维修

Repair should not be done after the LEDs have been soldered. When repairing is unavoidable, a double-head soldering iron should be used (as below figure). It should be confirmed in advance whether the characteristics of LEDs will or will not be damaged by repairing.

LED回流焊后不应该修复，当必须修复时，必须使用双头烙铁，而且事先应确认此种方式会不会损坏LED本身的特性。

### 3.1.3 Cautions 注意事项

(1) The encapsulated material of the LEDs is silicone. Therefore the LEDs have a soft surface on the top of package. The pressure to the top surface will be influence to the reliability of the LEDs. Precautions should be taken to avoid the strong pressure on the encapsulated part. So when use the picking up nozzle, the pressure on the silicone resin should be proper. LED封装胶为硅胶，表面较软，用力按压胶体表面会影响LED可靠性，因此应有预防措施避免在按压器件。当使用吸嘴时，胶体表面的压力应是恰当的。

(2) Components should not be mounted on warped (non coplanar) portion of PCB. After soldering, do not warp the circuit board. LED灯珠不要焊接在弯曲的PCB上，焊接后也不要弯曲电路板。

(3) Do not apply mechanical force or excess vibration during the cooling process to normal temperature after soldering. Do not rapidly cool device after soldering. 回流焊之后冷却过程中，不要对材料施加外力，也不要震动，回流焊后，不要采用激剧冷却的方式。

## 4. Handling Precautions 产品使用注意事项

### 4.1 Handling Precautions 产品使用注意事项

- (1) LED operating environment and sulfur element composition cannot be over 100PPM in the LED mating usage material. This is provided for informational purposes only and is not a warranty or endorsement. LED 工作环境及与 LED 透孔的材料中硫元素及化合物成份不可超过 100PPM. 这只是一个建议，不作任何品质担保。
- (2) In order to prevent external material from getting into the inside of LED, which may cause the malfunction of LED, the single content of Bromine element is required to be less than 900PPM, the single content of Chlorine element is required to be less than 900PPM, the total content of Bromine element and Chlorine element in the external materials of the application products is required to be less than 1500PPM. This is provided for informational purposes only and is not a warranty or endorsement. 为了防止外界物质进入 LED 内部以造成 LED 的损伤，所处环境及所用套件等等，单一的溴元素含量要求小于 900PPM，单一氯元素含量要求小于 900PPM，溴元素与氯元素总含量必须小于 1500PPM. 这只是一个建议，不作任何品质担保。
- (3) VOCs (Volatile organic compounds) emitted from materials used in the construction of fixtures can penetrate silicone encapsulants of LEDs and discolor when exposed to heat and photonic energy. The result can be a significant loss of light output from the fixture. Knowledge of the properties of the materials selected to be used in the construction of fixtures can help prevent these issues. Refond advises against the use of any chemicals or materials that have been found or are suspected to have an adverse affect on device performance or reliability. To verify compatibility, Refond recommends that all chemicals and materials be tested in the specific application and environment for which they are intended to be used. Attaching LEDs, do not use adhesives that outgas organic vapor. 应用套件中的挥发性物质会渗透到 LED 内部，在通电产生光子及热的条件下，会导致 LED 变色，进而造成严重光衰，提前了解套件材料能够避免产生这些问题。瑞丰反对使用任何对 LED 器件的性能或者可靠性有害的物质或材料，无论这些材料是已经证实过的还是仅仅怀疑有害，针对特定的用途和使用环境。瑞丰建议对所有的物质和材料进行相容性的测试。在贴装 LED 时候，不要使用能产生有机挥发性气体的粘结剂。
- (4) Handle the component along the side surface by using forceps or appropriate tools; do not directly touch or handle the silicone lens surface, it may damage the internal circuitry. 通过使用适当的工具从材料侧面夹取，不可直接用手或尖锐金属压胶体表面，它可能会损坏内部电路。



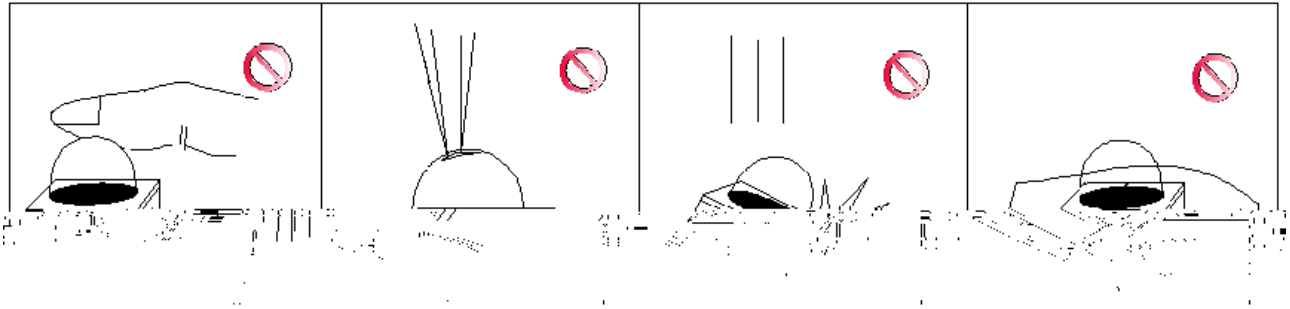

Fig 4-1

(5) In designing a circuit, the current through each LED can not be exceeded the absolute maximum rating specified for each LED. In the meanwhile, resistors for protection should be applied, otherwise slight voltage shift will cause big current change, burn out may happen. The driving circuit must be designed to allow forward voltage only when it is ON or OFF. If the reverse voltage is applied to LED, migration can be generated resulting in LED damage. 设计电路时，通过 LED 的电流不能超过规定的最大值。同时，还需使用保护电阻，否则，微小的电压变化将会引起较大电流变化，可能导致产品损毁。电路设计必须保证只有在开启或者关闭的时候出现正向电压的变化，不要施加反压，否则会损坏 LED。

(6) Thermal Design is paramount importance because heat generation may result in the Characteristics decline, such as brightness decreased, Color change and so on. Please consider the heat generation of the LEDs when making the system design. LED 会因为温度升高而导致亮度下降、颜色变化等，所以在设计时应充分考虑散热问题。

(7) Compared to standard encapsulants, silicone is generally softer, and the surface is more likely to attract dust, requiring special care during processing. In cases where a minimal level of dirt and dust particles cannot be guaranteed, a suitable cleaning solution must be applied to the surface after the sold5( )5(l)5(st)-(t)F3-6(t)5(e) )5(Co)

Table 4-1 Storage 儲存

| Conditions<br>种类 | Temperature<br>温度 | Humidity<br>湿度 | Time<br>时间 |
|------------------|-------------------|----------------|------------|
|------------------|-------------------|----------------|------------|

Before Opening Aluminum Bag

Storage 拆包前







Declare 申明

This specification is written both in English and in Chinese and the latter is formal.

产品规格书以中英文方式书写，若有冲突以中文版本为准。