

SPECIFICATION

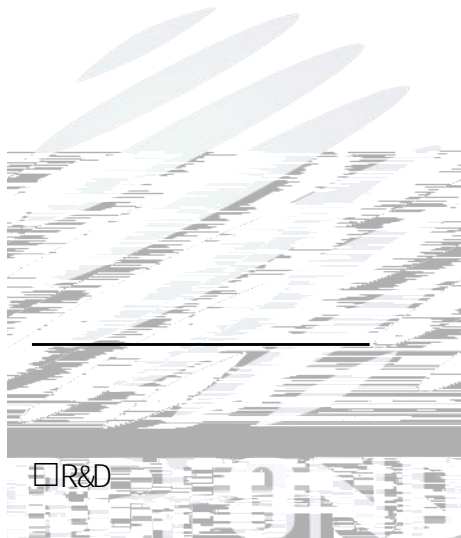

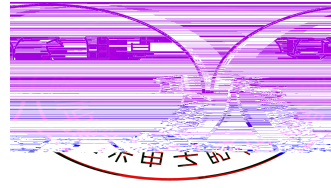

1. Description

1.1 General Description



1.2 Features



1.3 Application



1.4 Package Dimension

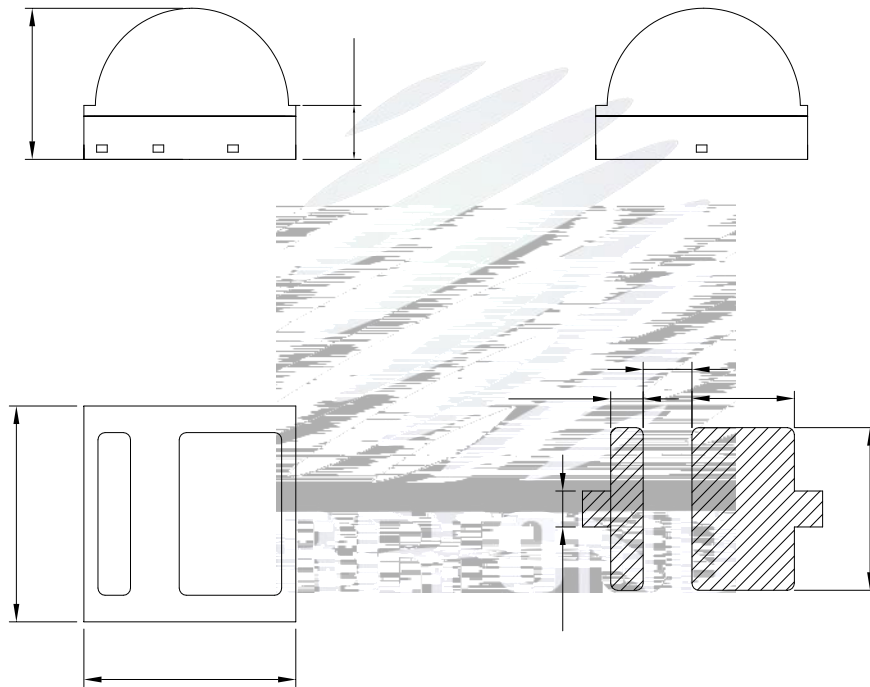
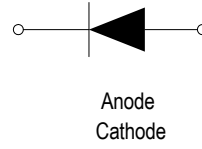
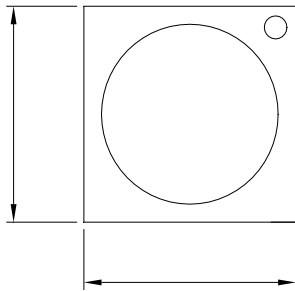

±



1.5 Product Parameters

	λ					

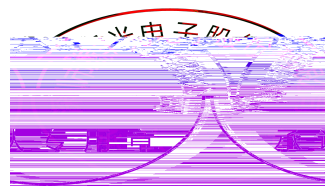

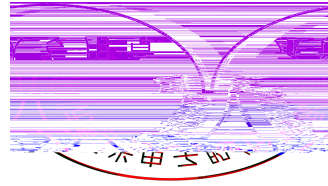

1.6 Typical optical characteristics curves

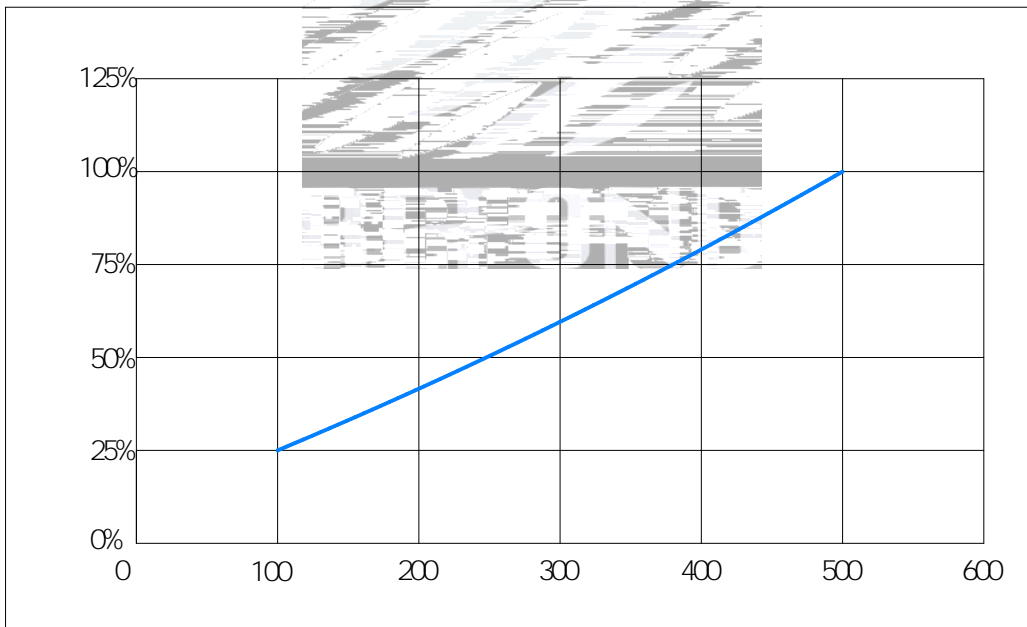
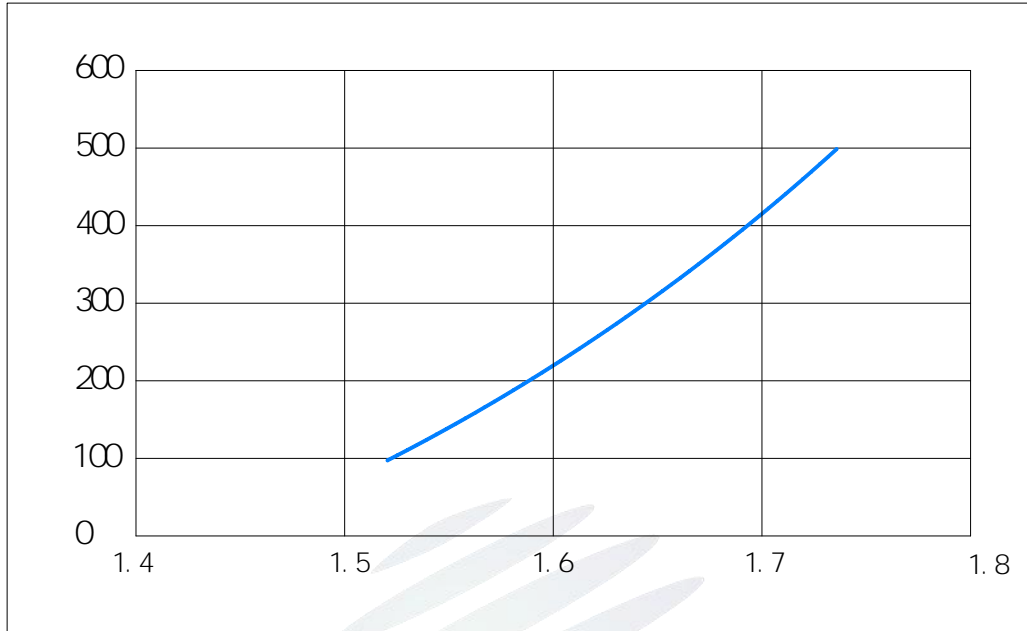

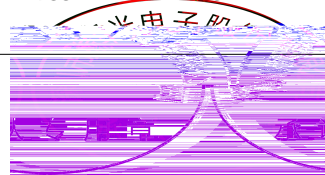
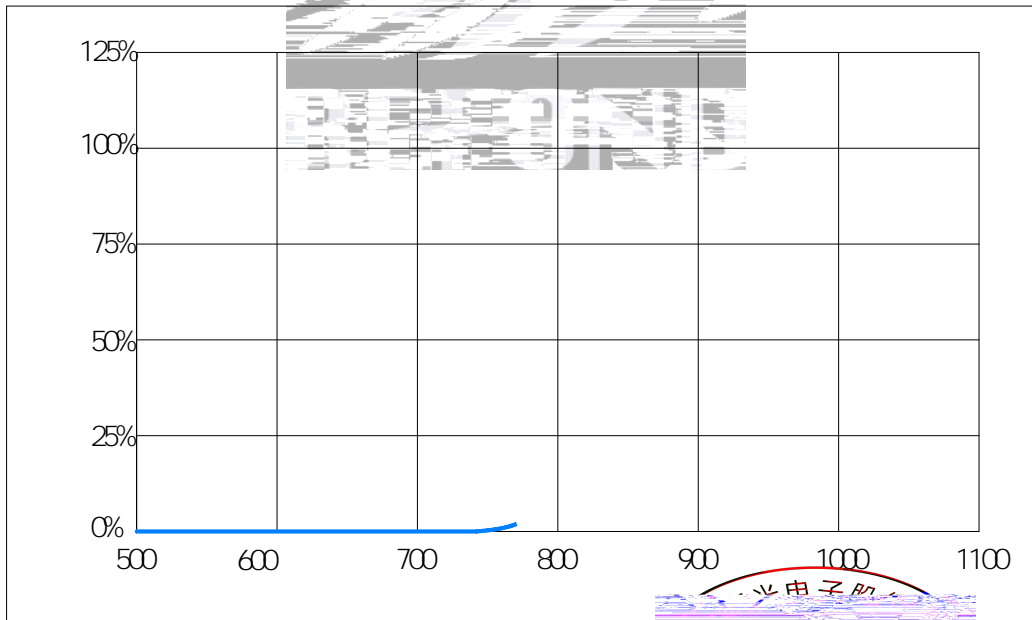
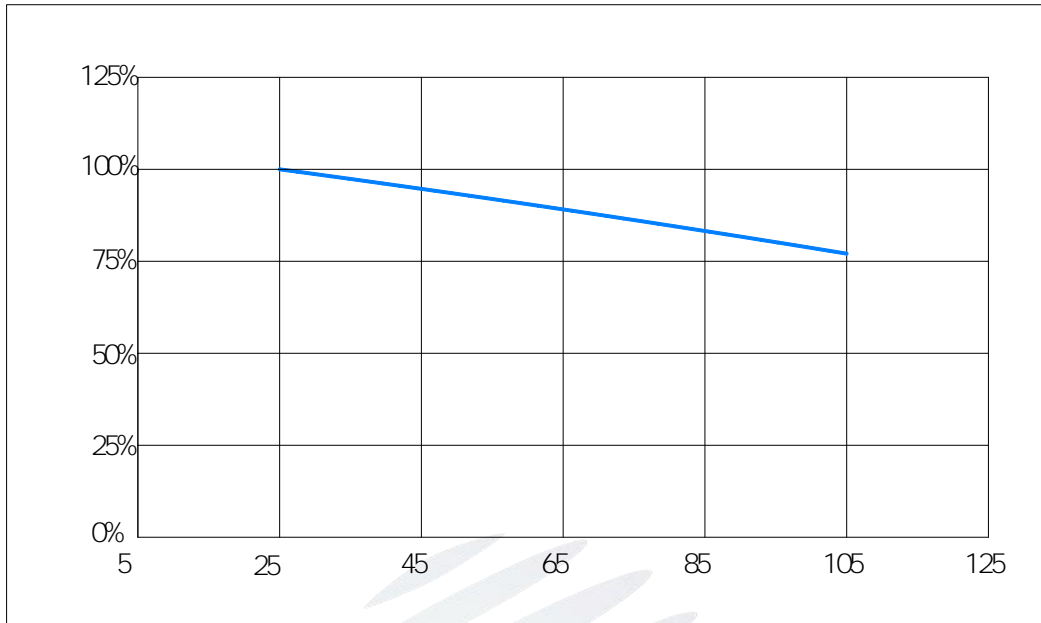

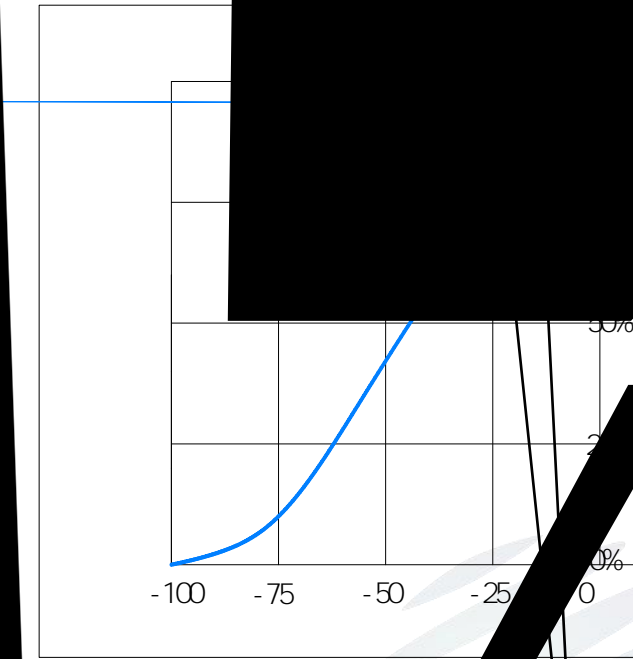

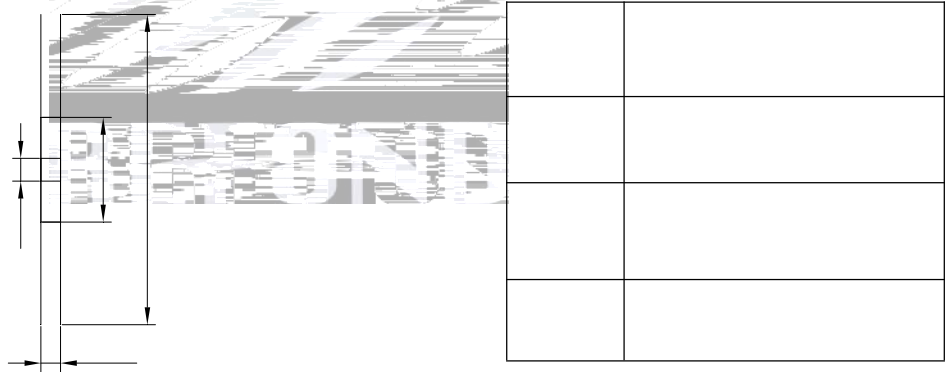
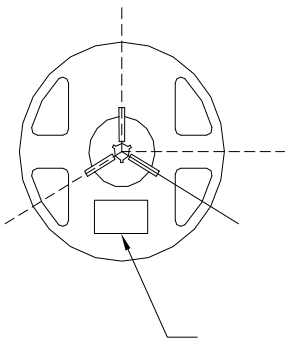
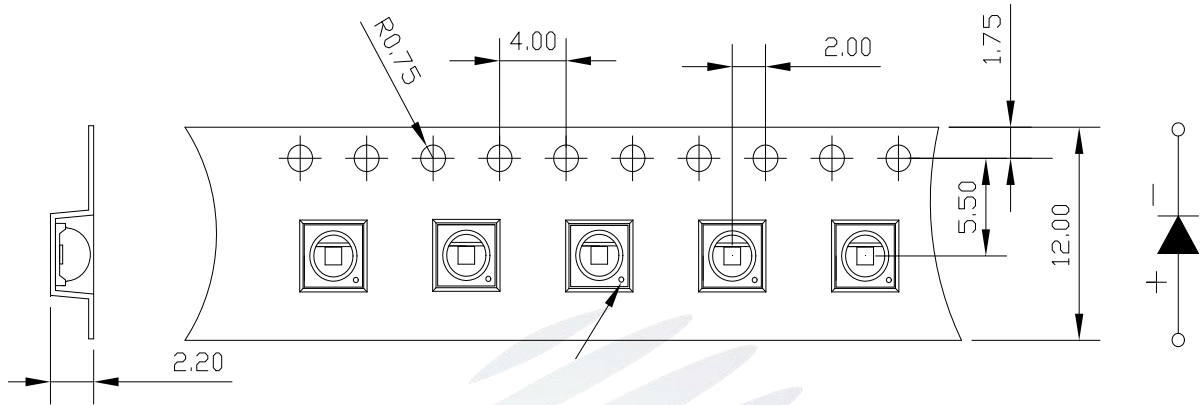

2. Packaging

2.1 Packaging Specification



PART NO.	
SPEC NO.	
LOT NO.	
<hr/>	
BIN CODE	
e	WLP
VF	
	QTY:
	DATE:

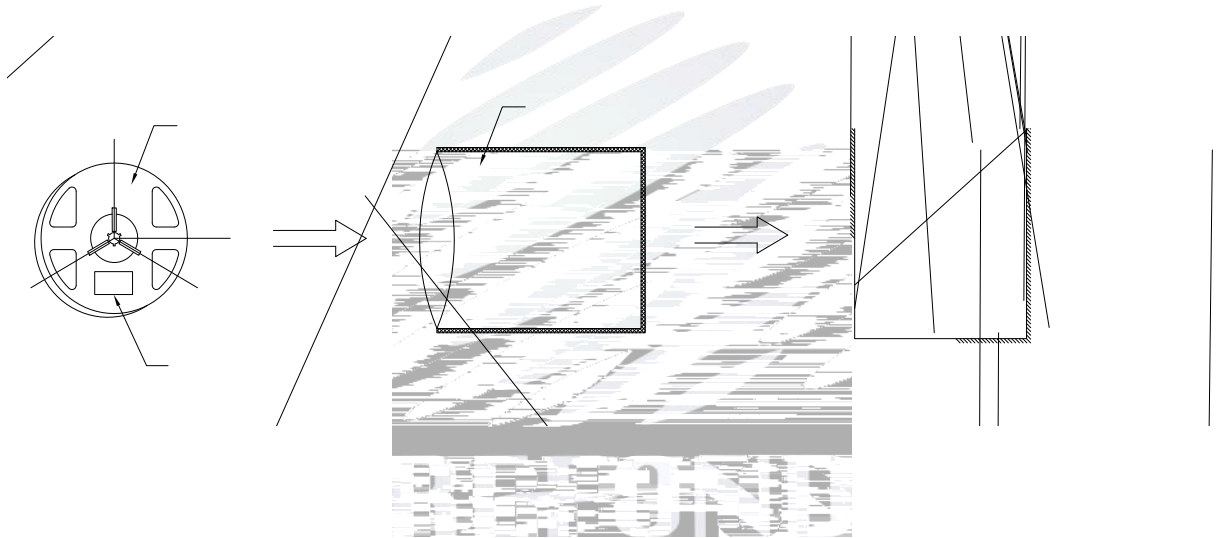

2.4 Reliability Test Items And Conditions



2.5 Criteria For Judging Damage

1.



3. SMT Reflow Soldering Instructions



3.1 SMT Reflow Soldering Instructions



°C

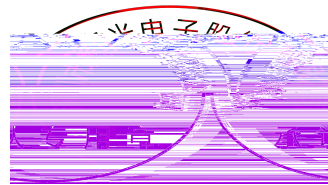

4. Handling Precautions

4.1 Handling Precautions

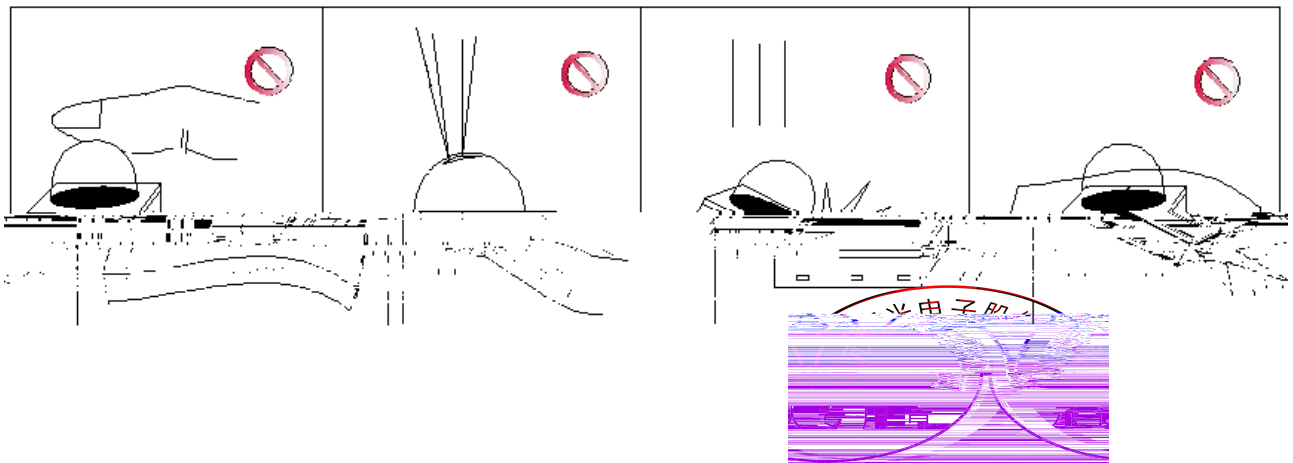

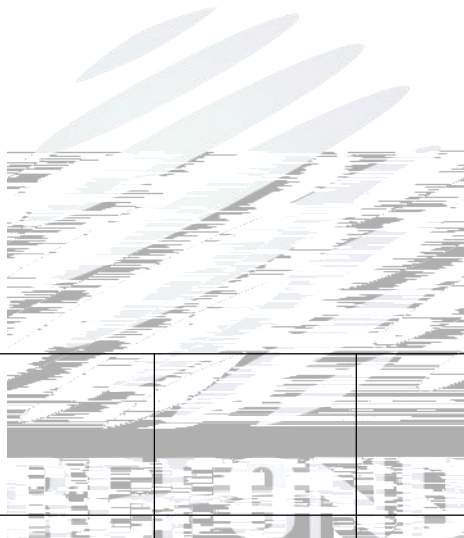

		士			

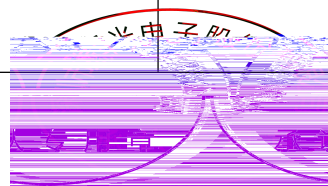

(7)

()

(±) °C



