

# SPECIFICATION 产品规格书

REFOND P/N 产品型号

RF-BU0402TS-CE-B1

R&D 研发

Mass Product 量产供货

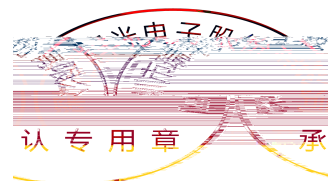



## 1. Description 产品介绍

### 1.1 General Description 产品描述

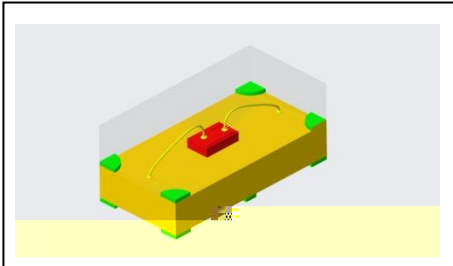

The Colour LED which was fabricated using a blue chip, Package Dimension : 1.0mmX0.5mmX0.4mm.

该产品为色光 LED，是由蓝光芯片封装形成，产品尺寸：1.0mmX0.5mmX0.4mm。

### 1.2 Features 产品特征

Extremely wide viewing angle. 发光角度大

Suitable for all SMT assembly and solder process. 适用于所有的SMT组装和焊接工艺

Moisture sensitivity level: Level 3. 防潮等级 Level3

RoHS compliant. 满足RoHS要求

### 1.3 Application 产品应用

Optical indicator. 光电指示

Switch and symbol, display. 开关和标志，显示器等

General use. 其他应用

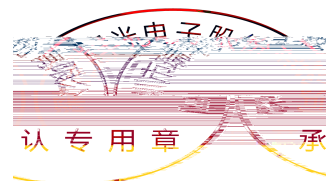

### 1.4 Package Dimension 封装尺寸

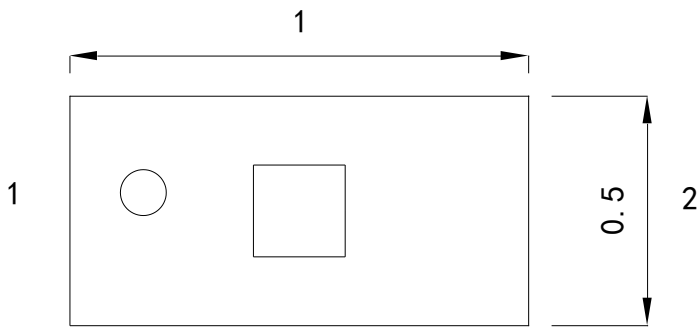

Fig.1-1 Top view 正面视图

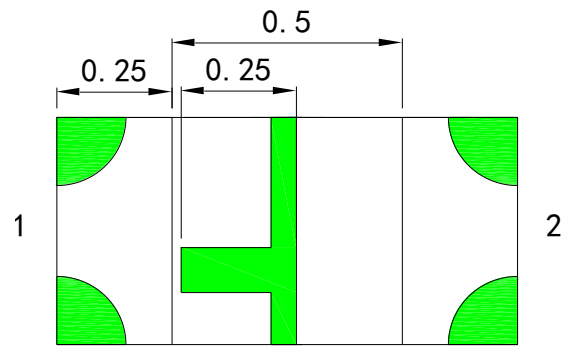

Fig.1-2 Bottom view 背面视图

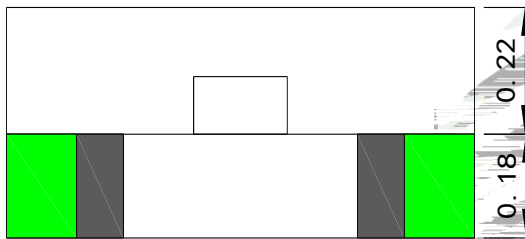

Fig.1-3 Side view 侧面视图

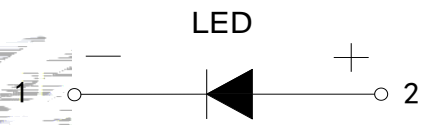
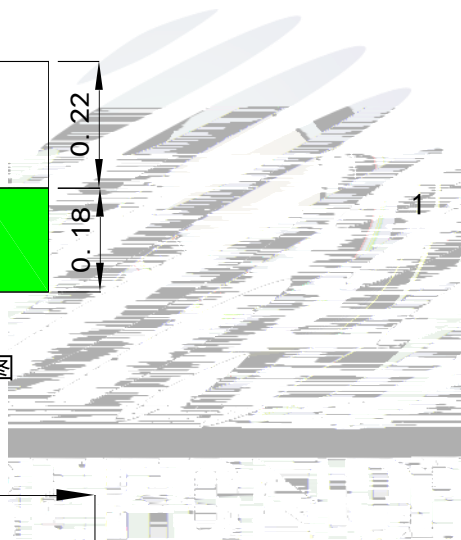

Fig.1-4 Polarity 极性



Fig.1-5 Soldering patterns 推荐焊盘

Notes 备注:

1. All dimensions units are millimeters. 所有尺寸标注单位为毫米
2. All dimensions tolerances are  $\pm 0.2\text{mm}$  unless otherwise noted. 除特别标注外, 所有尺寸公差为  $\pm 0.2$  毫米

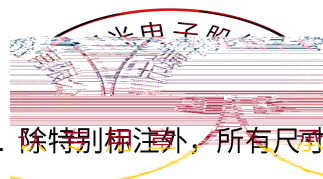

## 1.5 Product Parameters 产品参数

Table 1-1 Electrical / Optical Characteristics at Ts=25°C 电性与光学特性

| Item<br>项目                     | Test<br>Condition<br>测试条件 | Symbol<br>符号 | Value         |               |               | Unit<br>单位 |    |
|--------------------------------|---------------------------|--------------|---------------|---------------|---------------|------------|----|
|                                |                           |              | Min.<br>(最小值) | Typ.<br>(典型值) | Max.<br>(最大值) |            |    |
| Spectral Half Bandwidth<br>半波宽 | $I_F=5mA$                 | $\Delta$     | --            | 15            | --            | nm         |    |
| Forward Voltage<br>正向电压        | $I_F=5mA$                 | $V_F$        | D2            | 2.3           | --            | 2.4        | V  |
|                                |                           |              | E1            | 2.4           | --            | 2.5        | V  |
|                                |                           |              | E2            | 2.5           | --            | 2.6        | V  |
|                                |                           |              | F1            | 2.6           | --            | 2.7        | V  |
|                                |                           |              | F2            | 2.7           | --            | 2.8        | V  |
|                                |                           |              | G1            | 2.8           | --            | 2.9        | V  |
|                                |                           |              | G2            | 2.9           | --            | 3.0        | V  |
|                                |                           |              | H1            | 3.0           | --            | 3.1        | V  |
|                                |                           |              | H2            | 3.1           | --            | 3.2        | V  |
|                                |                           |              | I1            | 3.2           | --            | 3.3        | V  |
|                                |                           |              | I2            | 3.3           | --            | 3.4        | V  |
|                                |                           |              | J1            | 3.4           | --            | 3.5        | V  |
| Dominant Wavelength<br>主波长     | $I_F=5mA$                 | $\lambda_D$  | D10           | 465.0         | --            | 467.5      | nm |
|                                |                           |              | D20           | 467.5         | --            | 470.0      | nm |
|                                |                           |              | E10           |               |               |            |    |

Notes 备注:  $V_R=5V$  For test conditions.  $V_R=5V$  为测试条件

Table 1-2 Absolute Maximum Ratings at Ts=25°C 绝对最大值

Notes 备注:

1. 1/10 Duty cycle, 0.1ms pulse width. 脉宽0.1ms,占空比1/10.

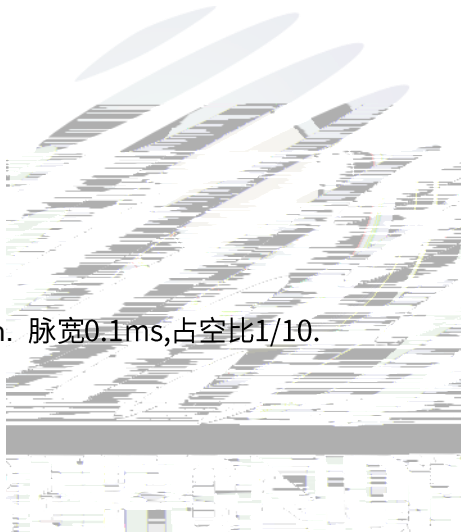

## 1.6 Typical Optical Characteristics Curves 典型光学特性曲线

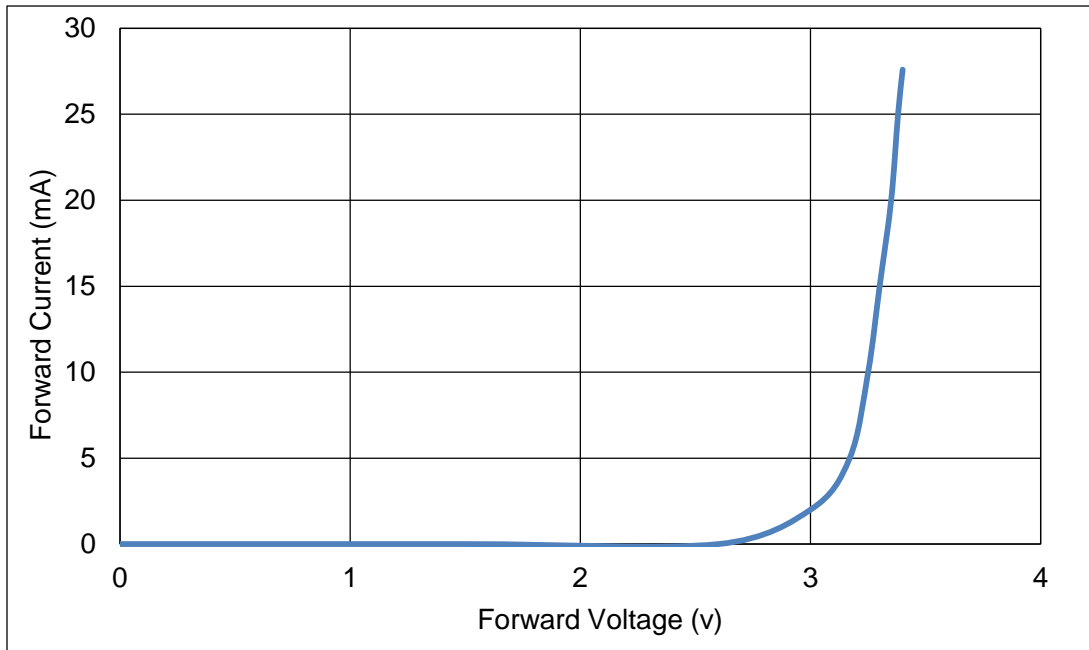

Fig 1-6 Forward Voltage Vs Forward Current 伏安特性曲线

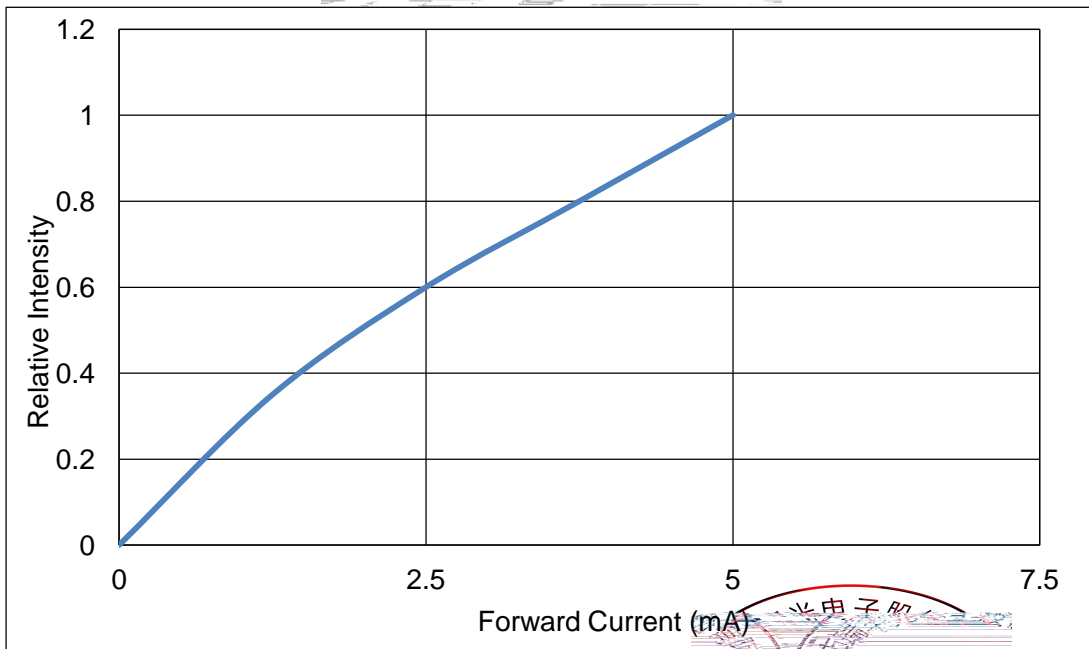

Fig 1-7 Forward Current Vs Relative Intensity 正向电流与相对光强特性曲线

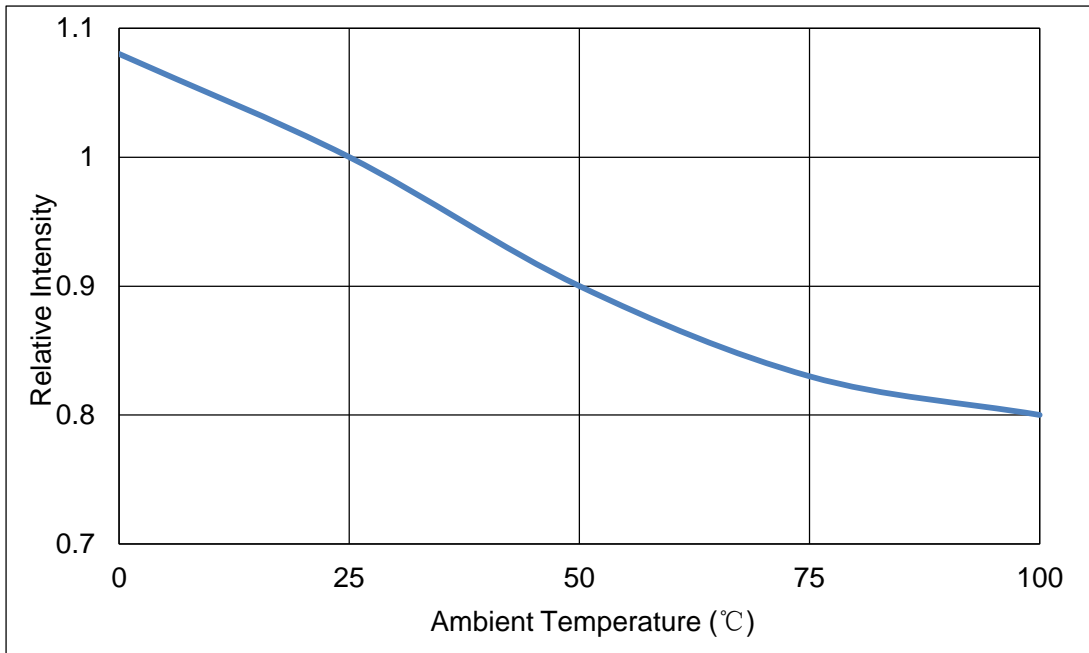

Fig 1-8 Pin Temperature Vs Relative Intensity 引脚温度与相对光强特性曲线

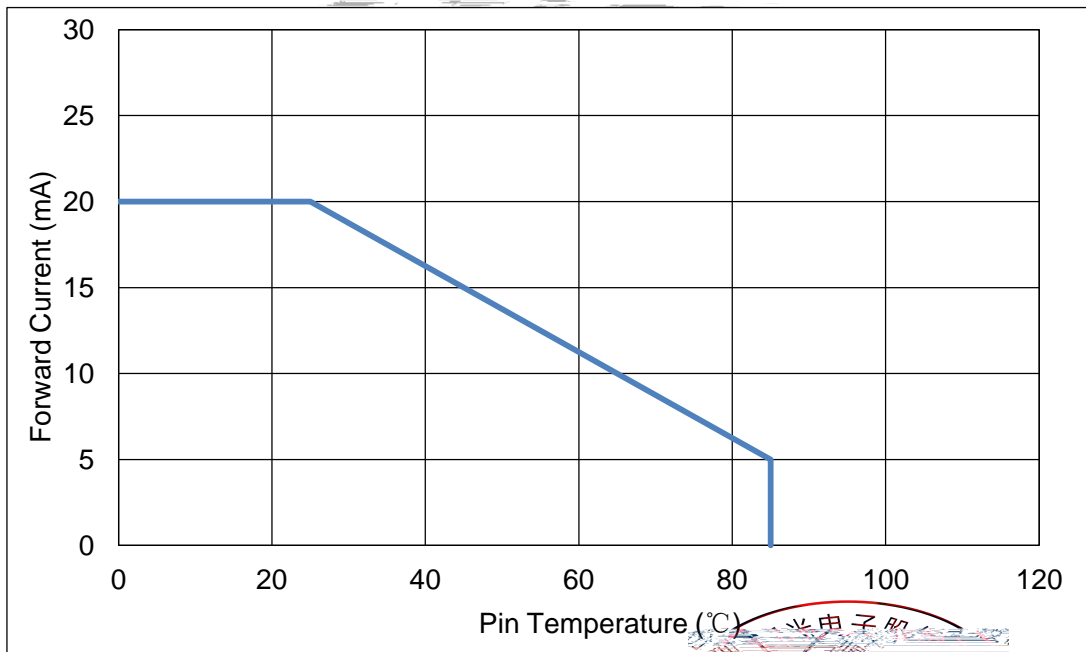
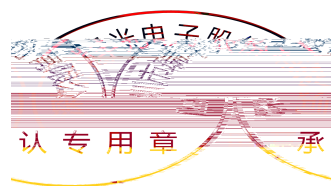

Fig 1-9 Pin Temperature Vs Forward Current 引脚温度与正向电流特性曲线





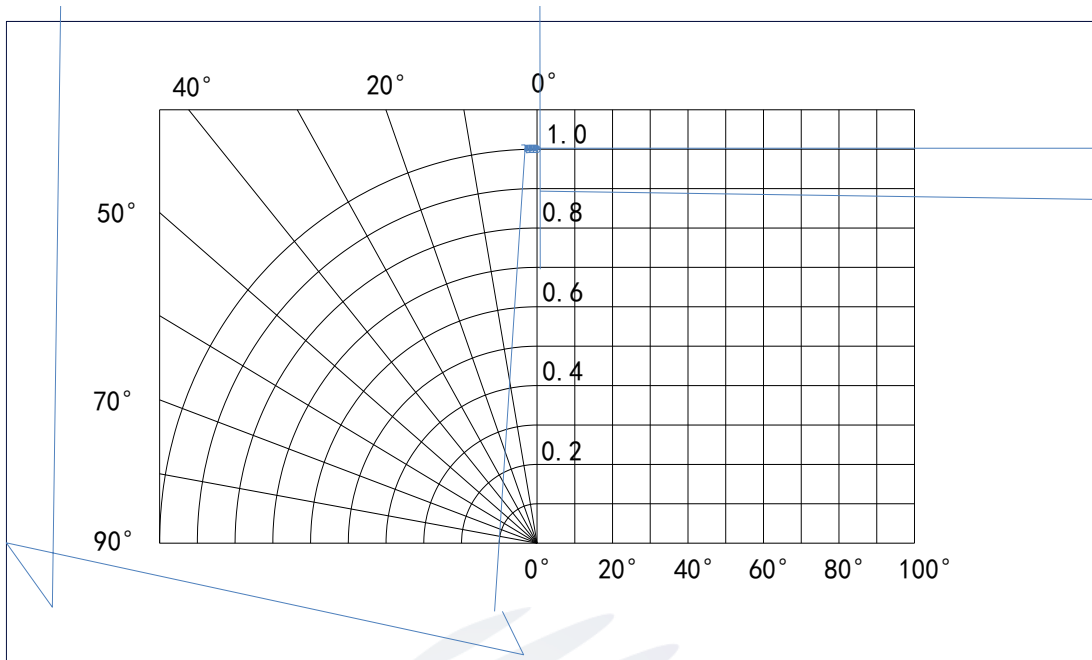
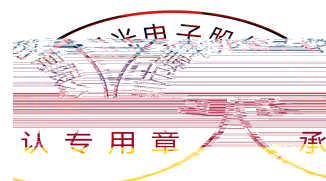

Fig 1-12 Diagram characteristics of radiation 辐射特性曲线



## 2. Packaging 产品包装

### 2.1 Packaging Specification 包装规格

Package:4000pcs/reel.包装每卷 4000pcs。

#### 2.1.1 Carrier Tape Dimension 载带尺寸

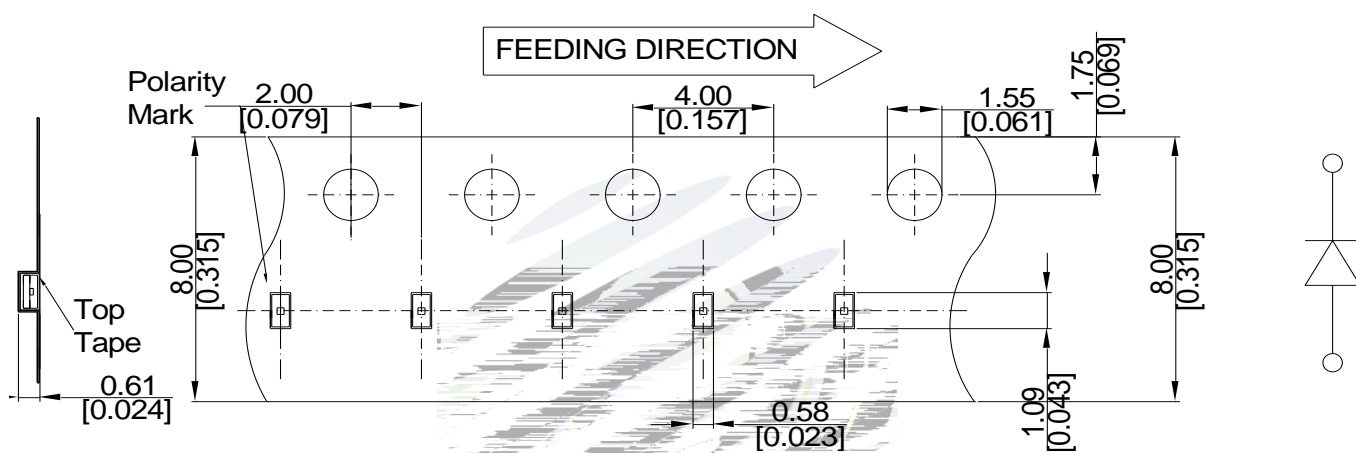

Fig.2-1 Carrier Tape Dimension 载带尺寸

#### 2.1.2 Reel Dimension 卷盘尺寸

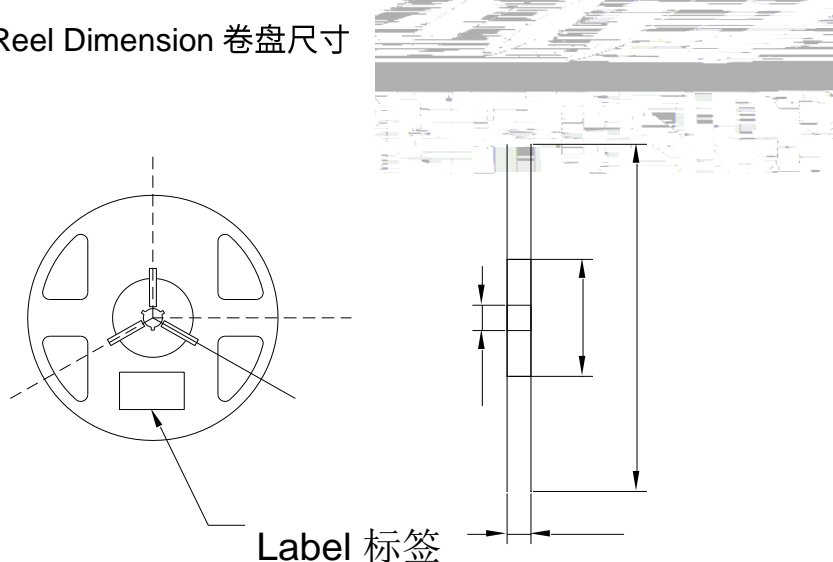
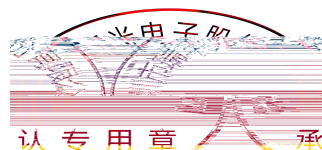

Table 2-1 Dimension 尺寸

|   |            |
|---|------------|
| A | 8.0±0.1mm  |
| B | 178±1mm    |
| C | 60±1mm     |
| D | 13.0±0.5mm |

Fig.2-2 Reel Dimension 卷盘尺寸

Notes 备注:



The tolerances unless mentioned  $\pm 0.1$ mm. Unit : mm 注: 未注公差为 $\pm 0.1$ 毫米, 尺寸单位: 毫米。

### 2.1.3 Label Form Specification 标签规格

Table 2-2 Parameter 参数



|                |                      |
|----------------|----------------------|
| PART NO.       | Part Number 品名       |
| SPEC NO.       | Spec Number 规格       |
| LOT NO.        | Lot Number 批次号       |
| BIN CODE       | Bin Code 参数代码        |
|                | Luminous flux 光通量    |
| XY             | Chromaticity Bin 色区  |
| V <sub>F</sub> | Forward Voltage 正向电压 |
| WLD            | Wavelength 波长代码      |
| QTY            | Packing Quantity 数量  |
| DATE           | Made Date 生产日期       |

Fig. 2-3 Label Form Specification 标签规格

### 2.2 Moisture Resistant Packing 防潮包装

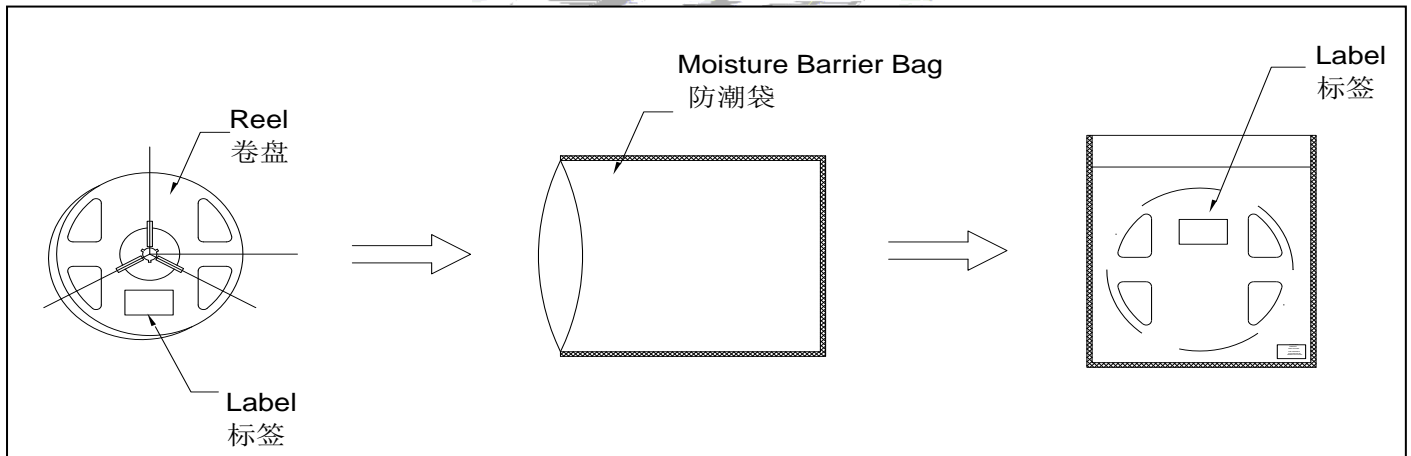
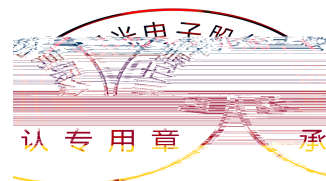

Fig.2-4 Moisture Resistant Packing 防潮包装



## 2.3 Cardboard Box 包装纸箱

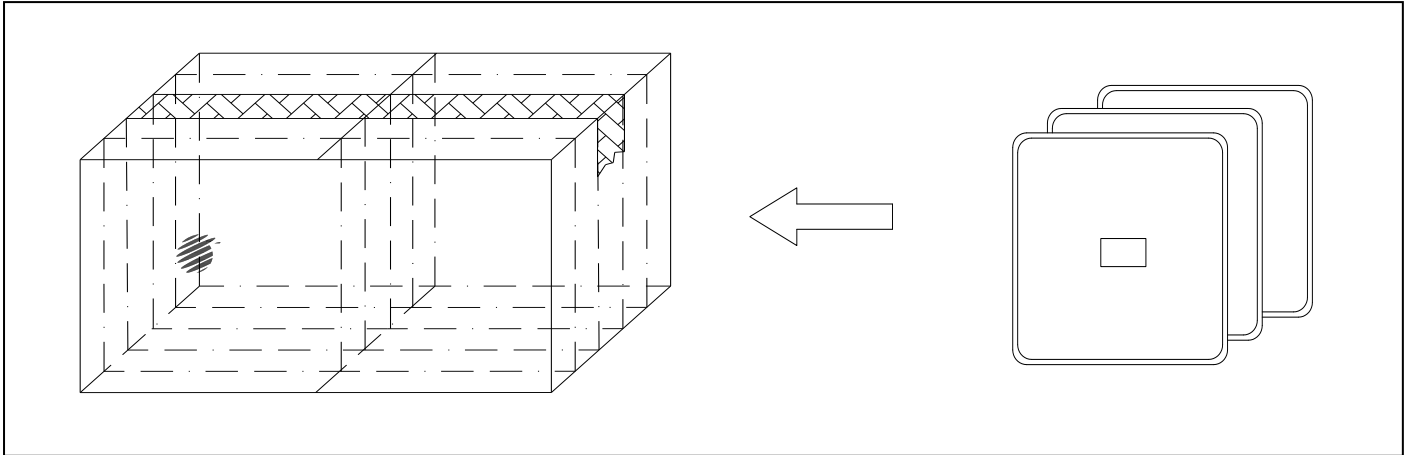

Fig.2-5 Cardboard Box 包装纸箱

## 2.4 Reliability Test Items And Conditions 信赖性测试项目及条件

Table 2-3 Reliability Test Items And Conditions 信赖性测试项目及条件

| Test Items<br>项目                 | Ref.Standard<br>参考标准 | Test Condition<br>测试条件                      | Time<br>时间 | Quantity<br>数量 | Ac/Re<br>接收/拒收 |
|----------------------------------|----------------------|---|------------|----------------|----------------|
| Reflow<br>回流焊                    | JESD22-B106          | Temp:260°Cmax<br>T=10 sec                   | 2 times    | 22Pcs.         | 0/1            |
| Temperature Cycle<br>温度循环        | JESD22-A104          | 100°C 30 min<br>5 min<br>-40°C 30 min       | 100 cycles | 22Pcs.         | 0/1            |
| Thermal Shock<br>冷热冲击            | JESD22-A106          | -40°C 15min<br>100°C 15min                  | 300 cycles | 22Pcs.         | 0/1            |
| High Temperature Storage<br>高温保存 | JESD22-A103          | Temp:100°C                                  | 1000 hrs.  | 22Pcs.         | 0/1            |
| Low Temperature Storage<br>低温保存  | JESD22-A119          | Temp:-40°C                                  | 1000 hrs.  | 22Pcs.         | 0/1            |
| Life Test<br>常温通电                | JESD22-A108          | T <sub>a</sub> =25°C<br>I <sub>f</sub> =5mA | 1000 hrs.  | 22Pcs.         | 0/1            |

## 2.5 Criteria For Judging Damage 失效判定标准

Table 2-4 Criteria For Judging Damage 失效判定标准

| Test Items<br>项目        | Symbol<br>符号 | Test Condition<br>测试条件 | Criteria For Judgement<br>判定标准 |             |
|-------------------------|--------------|------------------------|--------------------------------|-------------|
|                         |              |                        | Min. 最小                        | Max. 最大     |
| Forward Voltage<br>正向电压 | $V_F$        | $I_F=5mA$              | -                              | U.S.L*)x1.1 |
| Reverse Current<br>漏电流  | $I_R$        | $V_R= 5V$              | -                              | U.S.L*)x2.0 |
| Luminous Flux<br>光通量    |              | $I_F=5mA$              | L.S.L*)x0.7                    | -           |

### Notes 备注:

1.U.S.L: Upper standard level 规格上限 L.S.L: Lower standard level 规格下限

2.The above reliability tests is based on the verification of a single/strip LED of Refond's existing experimental platform,the reliability experiment was taken under good heat dissipation conditions. When customers applies the LED to the series and parallel circuit,should take consideration of all the factors such as the current, voltage distribution, heat dissipation and others. 以上可靠性测试是基于瑞丰现有实验平台单颗/条 LED 在良好散热条件验证下的结果。客户端将 LED 应用于串、并联线路时，需自行评估电流、电压分配、散热等问题。

3.The technical information shown in the data sheets is limited to the typical characteristics and circuit examples of the referenced products. It does not constitute the warranting of industrial property nor the granting of any license. 以上技术数据仅为产品的典型值，只作为参考，不作为任何应用条件及应用方式的保证。



### 3. SMT Reflow Soldering Instructions SMT 回流焊说明

#### 3.1



## Notes 备注:

(1)Reflow soldering should not be done more than twice. If more than 24 hours between the two solderings , LED will be damaged. 回流焊次数不可以超过两次, 两次回流焊的时间间隔如果超过24小时, LED可能由于吸湿而损坏。

(2)When soldering , do not put stress on the LEDs during heating.当焊接时, 不要在材料受热时用力压胶体表面。

## 3.1.1 Soldering Iron 烙铁焊接

(1) When do soldering by hand, keep the temperature of iron below less 300°C less than 3 seconds 当手工焊接时,烙铁的温度必须小于300°C, 时间不可超过3秒。

(2) Soldering by hand should be done only one time.手工焊接只可焊接一次。

## 3.1.2 Repairing 修复

Repairing should not be done after the LEDs have been soldered. When repairing is unavoidable,a double-head soldering iron should be used (as below figure). It should be confirmed in advance whether the characteristics of LEDs will or not be damaged by repairing.

LED回流焊后不应该修复。当必须修复时, 必须使用双头烙铁, 而且事先应确认此种方式会不会损坏LED本身的特性。

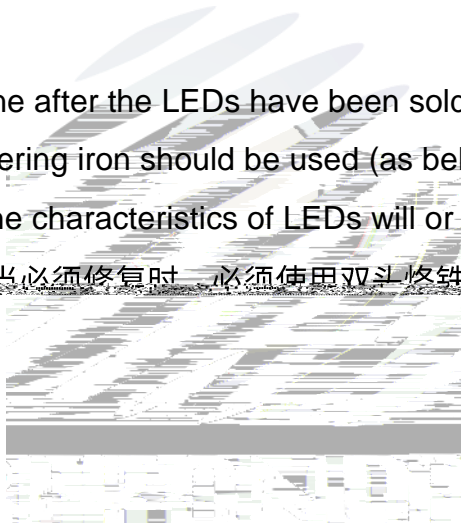

## 3.1.3 Cautions 注意事项

(1) Components should not be mounted on warped (non coplanar) portion of PCB. After soldering, do not warp the circuit board.LED 灯珠不要焊接在弯曲的 PCB 板上, 焊接之后, 也不要弯折线板。

(2) Do not apply mechanical force or excess vibration during the cooling process to normal temperature after soldering. Do not rapidly cool device after soldering.回流焊之后冷却过程中, 不要对材料施加外力, 也不要震动, 回流焊后, 不要采用激剧冷却的方式。

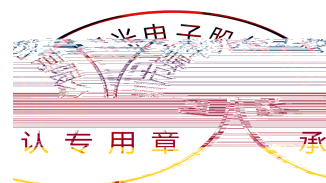



## 4. Handling Precautions 产品使用注意事项

### 4.1 Handling Precautions 产品使用注意事项

(1) LED operating environment and sulfur element composition can not be over 100PPM in the LED mating usage material. This is provided for informational purposes only and is not a warranty or endorsement. LED 工作环境及与 LED 适配的材料中硫元素及化合物成份不可超过 100PPM. 这只是一个建议，不作任何品质担保。

(2) In order to prevent external material from getting into the inside of LED, which may cause the malfunction of LED, the single content of Bromine element is required to be less than 900PPM, the single content of Chlorine element is required to be less than 900PPM, the total content of Bromine element and Chlorine element in the external materials of the application products is required to be less than 1500PPM. This is provided for informational purposes only and is not a warranty or endorsement. 为了防止外界物质进入 LED 内部以造成 LED 的损伤，所处环境及所用套件等等，单一的溴元素含量要求小于 900PPM，单一氯元素含量要求小于 900PPM，溴元素与氯元素总含量必须小于 1500PPM. 这只是一个建议，不作任何品质担保。

(3) VOCs (Volatile organic compounds) emitted from materials used in the construction of fixtures can penetrate silicone encapsulants of LEDs and discolor when exposed to heat and photonic energy. The result can be a significant loss of light output from the fixture. Knowledge of the properties of the materials selected to be used in the construction of fixtures can help prevent these issues. Refond advises against the use of any chemicals or materials that have been found or are suspected to have an adverse effect on device performance or reliability. To verify compatibility, Refond recommends that all chemicals and materials be tested in the specific application and environment for which they are intended to be used. Attaching LEDs, do not use adhesives that outgas organic vapor.

LED 内部，在通电产生光子及热的条件下，会导致 LED 变色，进而造成严重光衰，提前了解套件材料能够避免产生这些问题。瑞丰反对使用任何对 LED 器件的性能或者可靠性有害的物质或材料，不管这些材料是已经证实了的还是仅仅怀疑有害。针对特定的用途和使用环境，瑞丰建议对所有的物质和材料进行相容性的测试。在贴装 LED 时候，不要使用能产生有机挥发性气体的粘胶剂。

瑞豐光電  
認專用章 承

(4) In designing a circuit, the current through each LED can not exceed the absolute maximum rating specified for each LED. In the meanwhile, resistors for protection should be applied, otherwise slight voltage shift will cause big current change, burn out may happen. The driving circuit must be designed to allow forward voltage only when it is ON or OFF. If the reverse voltage is applied to LED, migration can be generated resulting in LED damage.

设计电路时，通过 LED 流过的电流不得超过其绝对最大额定值，同时应在每个 LED 两端加上保护电阻，微小的反向电压将会导致产品损毁。电路设计必须保证只有在开启或者关闭的时候出现正向电压的变化，不要施加反压，否则会损坏 LED。

(5) Thermal Design is paramount importance because heat generation may result in the Characteristics decline, such as brightness decreased, Color change and so on. Please consider the heat generation of the LEDs when making the system design. LED 容易因为自身的发热和环境温度的改变而改变，温度升高会降低 LED

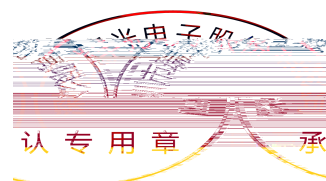
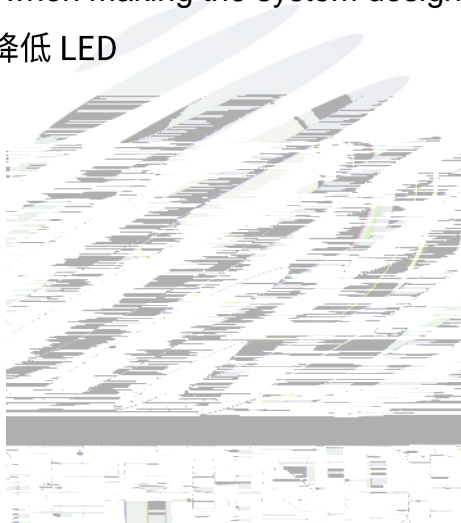

(8) Similar to most Solid state devices; LEDs are sensitive to Electro-Static Discharge (ESD) and Electrical Over Stress (EOS). 像其他的半导体电子器件一样，LED 对静电过流击穿非常敏感，需要做好防护。

(9) Other points for attention, please refer to our relevant information.其它注意事项请参照瑞丰相关资料

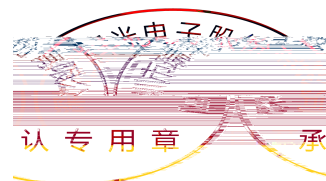



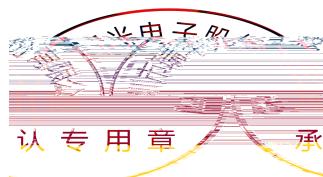

Declare 申明

This specification is written both in English and in Chinese and the latter is formal.

产品规格书以中英文方式书写，若有冲突以中文版本为准。