

SPECIFICATION

'a1w“ TT&ü

REFOND P/N 'a1w6 0?

RF-A3E31-WYSE-B1

Í 3 % pG0

ÍMass Production ¡€'a(Ø™

Contents naE6

1. Description 'a1w'•}O	3.....
1.1 General Description 'a1wL½•£.....	3.....
1.2 Features 'a1wfµE,,	3.....
1.3 Application 'a1wC¾k=.....	3.....
1.4 Package Dimension ? '3?o?	4.....
1.5 Product Parameters 'a1w/iO"	5.....
1.6 Bin Range Of Forward Voltage and Luminous Flux (IF=150mA)kO/"&x](PÈ- BIN ... '55 (IF=150mA)	6.....
1.7 Typical Optical Characteristics Curves ,)6 +Õ=ÖfµF•R<}A.....	8.....
2. Packaging 'a1w.«'3	12.....
2.1 Packaging Specification .«'3" TT	12.....
2.1.1 Carrier Tape Dimension œ¿C ?o?.....	12
2.1.2 Reel Dimension /wn9?o?	12
2.1.3 Label Form Specification SûvŠ" TT.....	13
2.2 Moisture Resistant Packing "È`Đ.«'3	13.....
2.3 Cardboard Box .«'3}:vò	13.....
2.4 Reliability Test Items And Conditions)L™FF•]5— -àna/úRđ'Ý.....	14.....
2.5 Criteria For Judging Damage 8βOj-<>ASû,¥.....	15.....
SMT Reflow Soldering Instructions SMT	16..
3.1 SMT Reflow Soldering Instructions SMT 5](cÒ—9PÈ.....	16..
4. Handling Precautions 'a1w(ªk=\\µH '2-à	18.....
4.1 Handling Precautions 'a1w(ªk=\\µH '2-à	18.....

1. Description 'a1w'•}O

1.1 General Description 'a1wL½•£

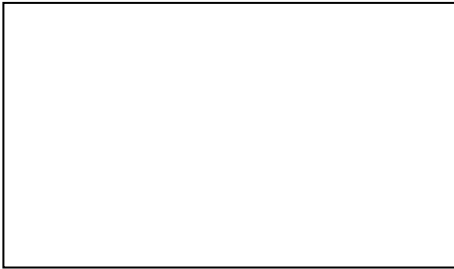

The Yellow LED, which was fabricated by using a blue chip and the phosphor.

Product Package:3.0mmX3.0mmX0.55mm.

—*'a1w&1.•+Õ- & %æ{PýkK%°+Õ,,ÿfYah0 †f+ÕxË·\ENÍæ{'a1w?o? m803.0mmX0.55mm

1.2 Features 'a1wfµE,,

EMC Package. & . \$ '3

Extremely wide viewing angle.0 +Õ“-CP8Đ

Suitable for all SMT assembly and solder process.•Ók='5J>Rcm, 4 . }F'31\$còLyB“,œ

Available on tape and reel.•Ók='5æ¿C /ú/wœ¶

Moisture sensitivity level: Level 2.È`Đv }) - F W F M

RoHS compliant. _Ø™ÈRoHS'3[

Qualifications: The product qualification test plan is based on the guidelines of AEC-Q102 Stress Test Qualification for Automotive Grade Discrete Semiconductors™4TTö;'a1w™4TT]5— -æ-"6Ç'5 " & \$2 [üœ")- u/(1? (dC¾.]5— ™4TT,¥--

1.3 Application 'a1wC¾k=

Automotive Lighting Interior and Exterior. [üœ",;©Ñ1\$8ª©Ñd'PÈ

1.4 Package Dimension ? '3'o?

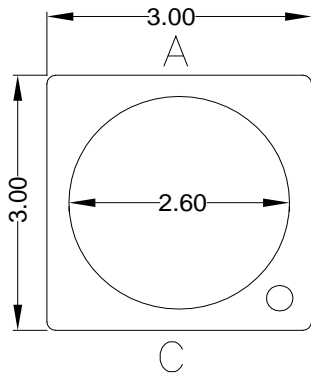

Fig.1-1 Top View

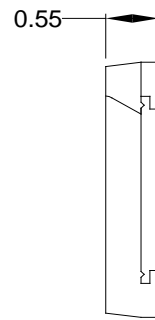

Fig.1-2 Side View

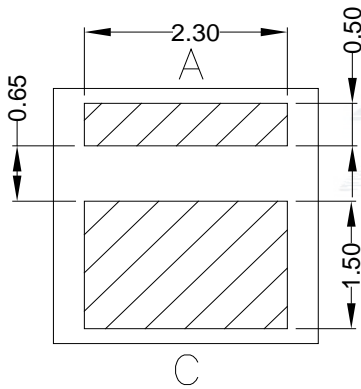

Fig.1-3 Bottom View

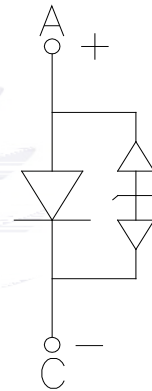

Fig.1-4 Polarity

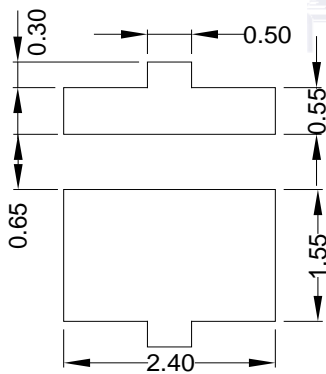

Fig.1-5 Soldering Patterns

Notes 8Š\pö;

All dimensions units are millimeters. J>Rc?o? Sù\p/@(Y&1[x)

All dimensions tolerances are 0.2mm unless otherwise noted.© fμ-FSù\p8ªæ{J>Rc?o? , Bμ&1 p [x)

1.5 Product Parameters 'a1w/iO"

Table 1-1 Electrical / Optical Characteristics at Ts=25°C kOF•&x+Ö=ÖfµF•

Item àna	Symbol ux0?	Test Condition]5— Rõ'Y	Value			Unit /@(Y
			Min. æwRR?-)éæ	Typ. æw,)6)éæx	Max. æwRR8Ð)éæ	
Forward Voltage æwYû0bkO/"æx	V _F	I _F =150mA	2.8	---	3.4	V
Reverse Current æw/ÿ0bkO](æx	I _R	V _R =5V	---	---	10	µA
Luminous Flux æw+Öž j€æx		I _F =150mA	40.9	---	61.2	lm
Viewing Angle æw0 +Ö"-Cpæx	2 1/2	I _F =150mA	---	120	---	deg
Thermal Resistance. æwcs"Öæx	R _{THJ-S}	I _F =150mA	---	14	18	/W

Table 1-2 Absolute Maximum Ratings at Ts=25°C }_? RR8Ð)é

Parameteræw/iO"æx	Symbolæwux0?æx	Ratingæw)éæx	Unitsæw/@(Yæx
Power Dissipation æw. •ræx	P _D	1020	mW
Forward Current			

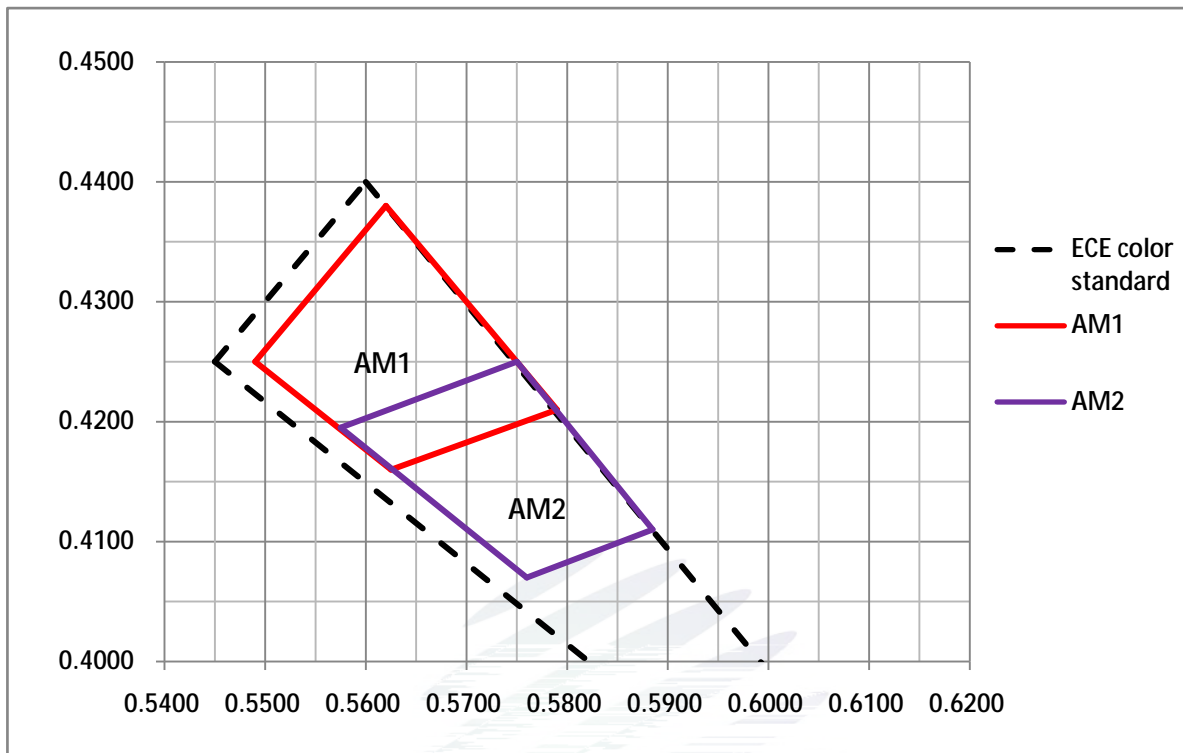

Fig. 1-6 The C.I.E Chromaticity Diagram CIE,€Cb5C

Table 1-4

BIN CODE	CIE-X1	CIE-Y1	CIE-X2	CIE-Y2	CIE-X3	CIE-Y3	CIE-X4	CIE-Y4
AM1	0.5625	0.4160	0.5490	0.4250	0.5620	0.4380	0.5790	0.4210
AM2	0.5760	0.4070	0.5575	0.4195	0.5750	0.4250	0.5885	0.4110

1.7 Typical Optical Characteristics Curves



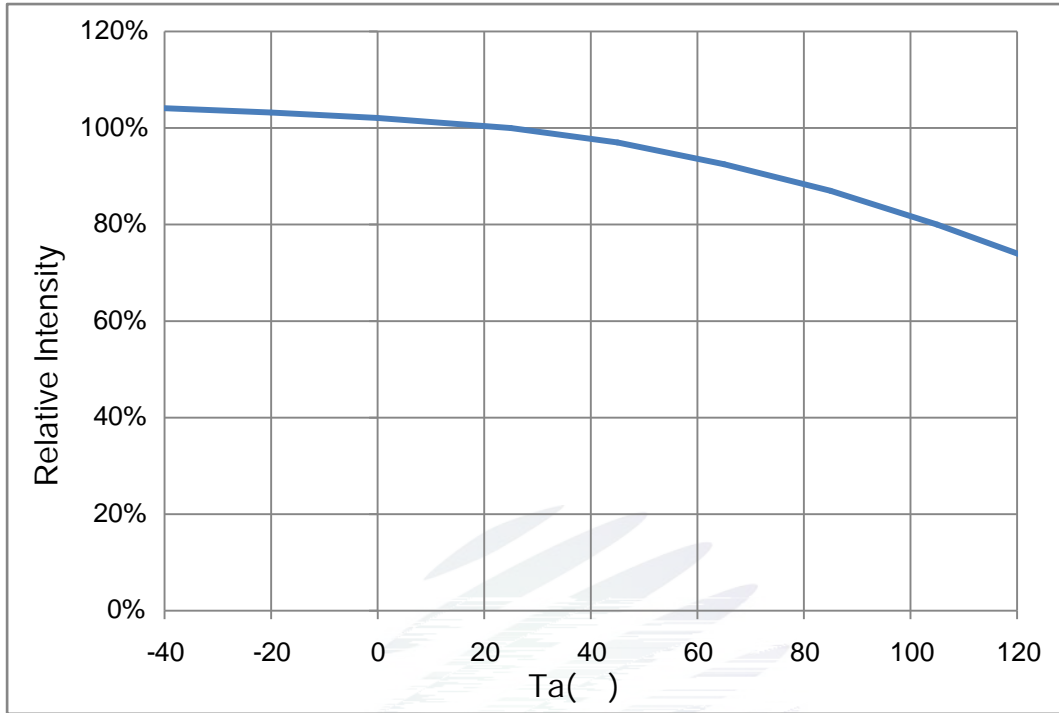

Fig. 1-9 Solder Temperature Vs Relative Intensity

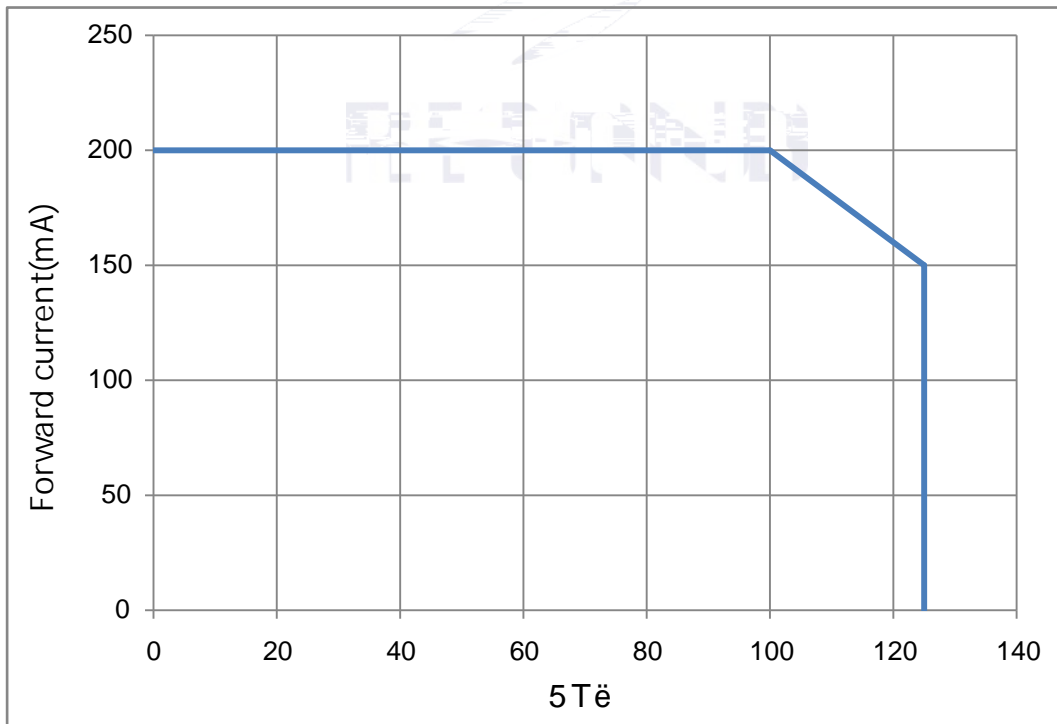

Fig. 1-10 Solder Temperature Vs Forward Current

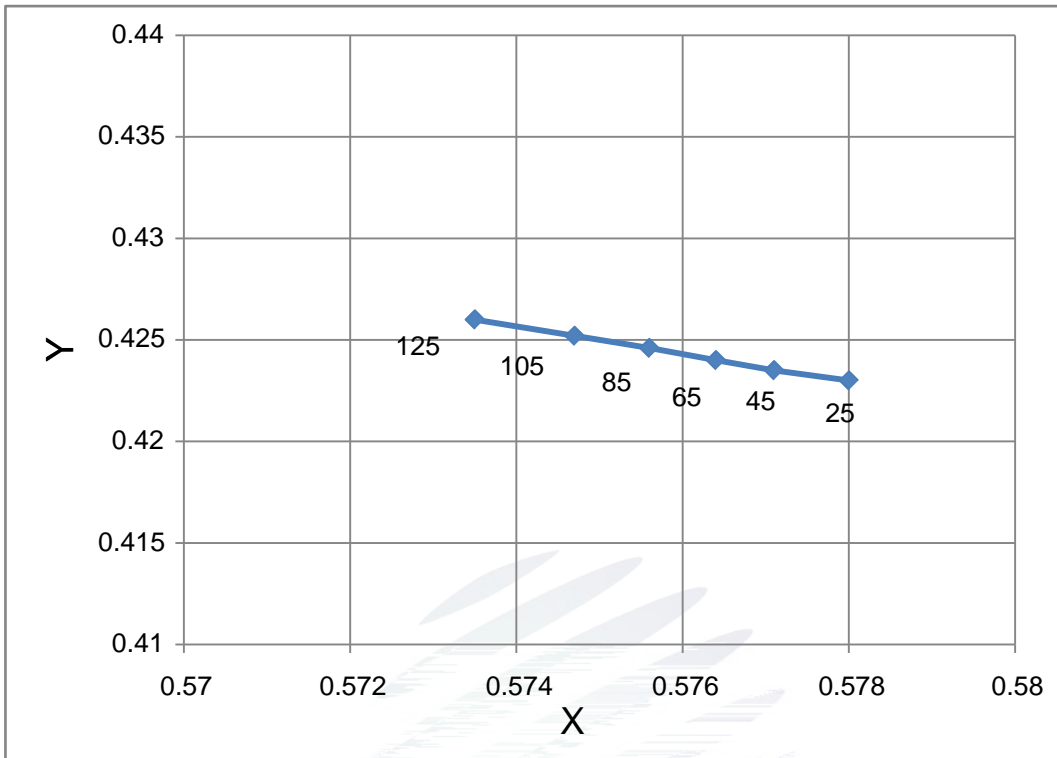

Fig. 1-13 Chromaticity Coordinate Vs Solder Temperature

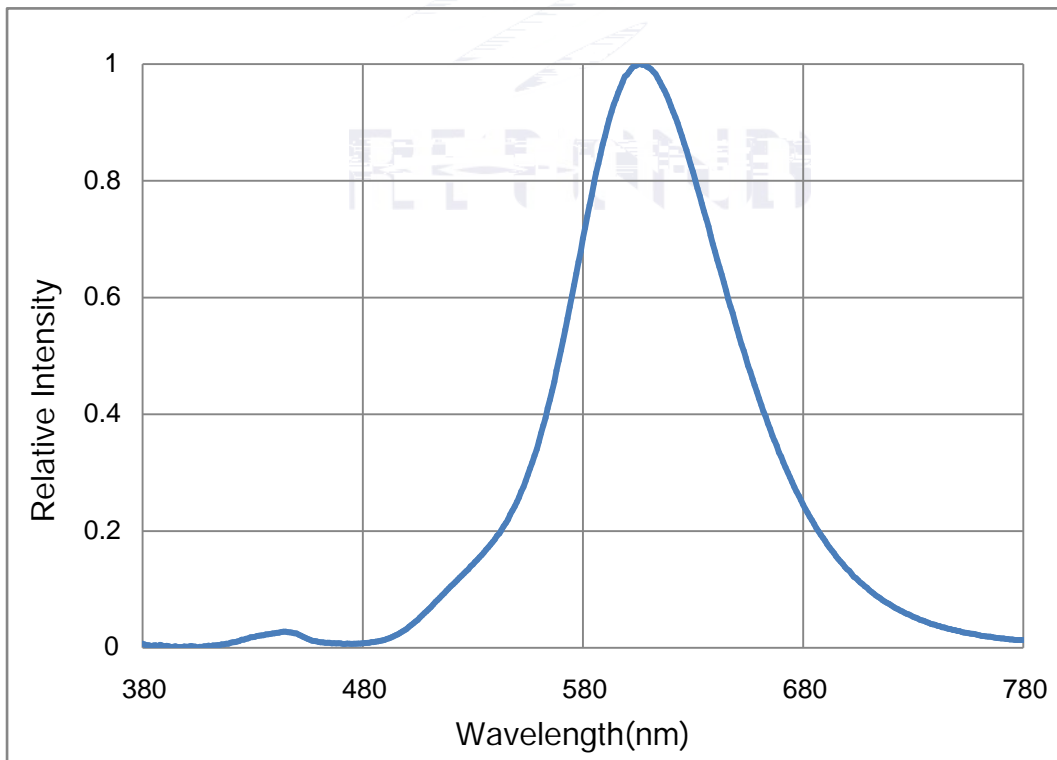

Fig. 1-14 Spectrum Distribution

2. Packaging 'a1w.«'3

2.1 Packaging Specification .«'3" TT

Package:4000pcs/reel..«'3Zæ/w4000pcso

2.1.1Carrier Tape Dimension œ¿C ?o?



Fig.2-1 Carrier Tape Dimension œ¿C ?o?

2.1.2Reel Dimension /wn9?o?



5 B C M Reel Dimension /wn9?o?

A	12 p 0.1mm
B	180 p 1mm
C	60 p 1mm
D	13.0 p 0.5mm

Fig.2-2Reel Dimension /wn9?o?

Notes 8Š\pö;

The tolerances unless mentioned $\pm 0.1\text{mm}$. Unit : mm\pö;Rç\p, Bµ&¹ p [x'æ{?o? /@ (Yö; [x' o

2.1.3 Label Form Specification SûvŠ“ TT

B C M F Specification“ TT

PART NO.	Part Number 1w0\
SPEC NO.	Spec Number“ TT
LOT NO.	Lot Number J Yf0?
BIN CODE	Bin Code /iO”¿p&
	Luminous flux +Öž j€
XY	Chromaticity Bin „€/
V _F	Forward Voltage Yû0bkO/“
WLD	Wavelength \ššË'¿p&
QTY	Packing Quantity O”j€
DATE	Made Date k0'aP^R•

Fig. 2-3 Label Form Specification SûvŠ“ TT

2.2 Moisture Resistant Packing “È`Đ.«‘3



Fig.2-4 Moisture Resistant Packing “È`Đ.«‘3

2.3 Cardboard Box .«‘3}:vò

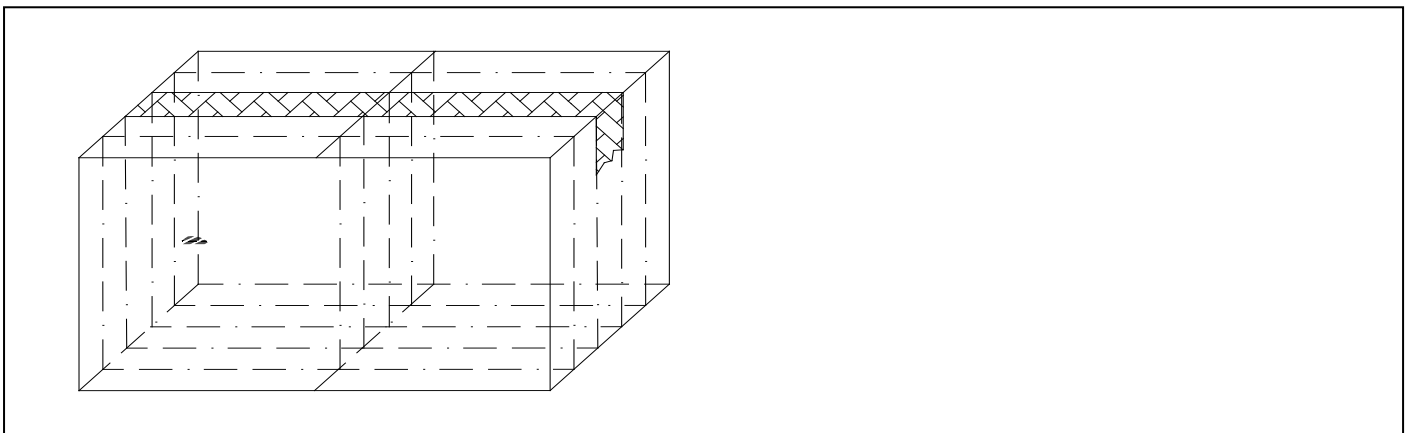

Fig.2-5 Cardboard Box .«‘3}:vò

2.4 Reliability Test Items And Conditions)L™FF•]5— -àna/úRõ'Ý

Table 2-3 Reliability Test Items And Conditions)L™FF•]5— -àna/úRõ'Ý

Test Items -àna	Ref.Standard /i•LSÙ,¥	Test Condition]5— Rõ'Ý	Time Pž",	Quantity O"j€	Ac/Re LyOPK(OP
Reflow 5](cÒ	JESD22-B106	Temp:260 ë max T=10 sec	2times	20pcs.	0/1
MSL2 "È`Đv }2	JESD22-A113	85 ë/ 60%RH	168 hrs.	20pcs.	0/1
Thermal Shock ,†cš,--	JEITAED-4701 300307	-40 ë 15min 10s 125 ë 15min	1000 cycle	20pcs.	0/1
Life Test ± ^)]5—	JESD22-A108	Ta=105 ë If=150mA	1000hrs.	20pcs.	0/1
High Temperature High Humidity Life Test ± ^)± _*]5—	JESD22-A101	85 ë/ 85%RH If=150mA	1000hrs.	20pcs.	0/1

SMT Reflow Soldering Instructions SMT

3.1 SMT Reflow Soldering Instructions SMT 5 [(c0-9PE

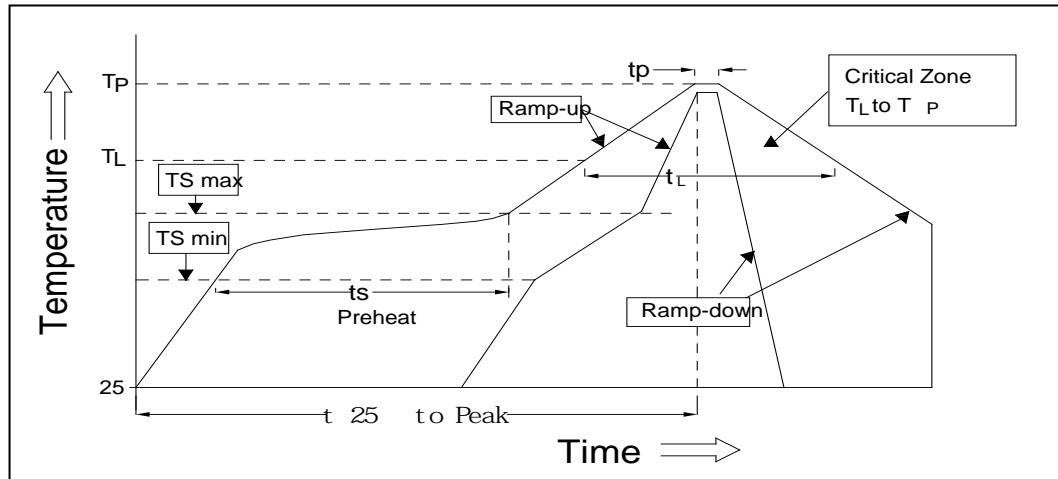

Fig.3-1 SMT Reflow Soldering Instructions SMT 5 [(c0-9PE

Table 3-1 Reflow parameters

Average temperature rise speed $C_{50} / (T_{max} - T_{preheat})$	RR ± 3 °C/s Max 3 °C/ s
Preheating: minimum temperature T_{min}	150 °C
Preheating: Max temperature T_{max}	200 °C
Preheating: Time t_s	60 - 120s 60s-120s
Time limited to maintain high temperature: the temperature T_L	217 °C
Time limited to maintain high temperature: The Time t_L	RR 60s Max 60s
Peak /Classification of temperature: T_p	260 °C
Time limit classification of peak temperature time t_p	RR 10s Max 10s
Hold time within 5 °C with the actual peak temperature (T_p)	RR 30s Max 30s
Cooling speed	RR ± 6 °C/s Max 6 °C/ s
Needed time from 25 °C to T_p	RR 8-12 Max 8 minutes

Notes 8Š\ǎö;

(1)Reflow soldering should not be done more than twice. If more than 24 hours between the two solderings ,LED will be damaged. 5](cÖYfO"&v03'Ä™,,•B&™Yfæ(&™Yf5](cÖm,Pž",;©I9uSS™,,•B ?-Pžæ&- & % •JkK'50"_*•L 5Á o

(2)When soldering , do not put stress on the LEDs during heating.E2cÖLyPžæ{&v'35^RPOñ0 cšPžk=. /"•8(d••« o

3.1.1 Repairing)]•%o

Repairing should not be done after the LEDs have been soldered. When repairing is unavoidable,a double-head soldering iron should be used (as below figure). It should be confirmed in advance whether the characteristics of LEDs will or not be damaged by repairing.

LED5](cÖ0_&vC¾—*)]8•æ{E2Eó-â)}8•Pžæ{Eó-â(âk=/ý8âcz§ æ{•\&,'2+ÓC¾pÁ-éYüs+POD-(&v(L 5ÁR&g% m,fµF• o

3.1.2 Cautions \ǎH '2-à

(1) The encapsulated material of the LEDs is silicone. Therefore the LEDs have a soft surface on the top of package. The pressure to the top surface will be impacted on the reliability of the LEDs. Precautions should be

REFOND

4. Handling Precautions 'a1w(ak=\#H '2-à

4.1 Handling Precautions 'a1w(ak=\#H '2-à

(1) LED operating environment and sulfur element composition cannot be over 100PPM in the LED mating usage material. This is provided for informational purposes only and is not a warranty or endorsement. LED B”(r h 7/ú&x - & %Ó •m, RPOn&#p»+Ëz /ú.Ê0VfYlí'ç&v03™,,•B 1 1 .•o0+Pý&g&jDŠ-óæ&v(r'ã(f1w™ K)B o

(2) In order to prevent external material from getting into the inside of LED, which may cause the malfunction of LED, the single content of Bromine element is required to be less than 900PPM, the single content of Chlorine element is required to be less than 900PPM, the total content of Bromine element and Chlorine element in the external materials of the application products is required to be less than 1500PPM. This is provided for informational purposes only and is not a warranty or endorsement. &'+"ÉYú8^krfY™ •s, - & %ÿË'Äž#lí - & % m, L (æ{J>8...h 7/úJ>k=9 'Yv v æ{/@&gm, _f+Ëz 0Žj€'3[]?-'5 1 1 .æ{/@&g[^+Ëz 0Žj€'3[]?-'5 1 1 .æ{ _f+Ëz &x[^+Ëz F^0Žj€Eó-â?-'5 1 1 . •o0+Pý&g&jDŠ-óæ&v(r'ã(f1w™ K)B o

(3) VOCs (Volatile organic compounds) emitted from materials used in the construction of fixtures can penetrate silicone encapsulants of LEDs and discolor when exposed to heat and photonic energy. The result can be a significant loss of light output from the fixture. Knowledge of the properties of the materials selected to be used in the construction of fixtures can help prevent these issues. Refond advises against the use of any chemicals or materials that have been found or are suspected to have an adverse effect on device performance or reliability. To verify compatibility, Refond recommends that all chemicals and materials be tested in the specific application and environment for which they are intended to be used. Attaching LEDs, do not use adhesives that outgas organic vapor. C^k=9 'Y&#m, K!0 F•fY™ (^w•ó-L - & %ÿËæ{5^ž kO'ak0+Õ=©/úcšm, Rō'Y &tæ{(? f] - & % „æ{s•ž#lí&šj~+Õ••æ{Lç-x'+R9 'YRPOn•J8çÿ +Y'ak0•o'H"-ÿ oi°&^/ÿ? (ak='ã(f? - & % 4<'Ym, F•Jlô•O03« F•Rc>rm, fY™ lôRPOnæ{&v vx•o'HRPOñPýB^Q— >J+m, •nPý""FUKßRc>r oi? fμ>Am, k=ž 1\$ (ak=h 7-æ{í°&^DŠ-ó? J>Rcm, fY™ 1\$RPOn•s•dnq>, F•m,]5— o5^™\$'3& %ž)«æ{&v^3(ak=•J'ak0RcR¼K!0 F•[^(d m, xè)U-k o

(4) Handle the component along the side surface by using forceps or appropriate tools; Do not directly touch or Handle the silicone lens surface, it may damage the internal circuitry. ž •B(ak=•ÓE2m, B", (çRPOn(é« 8ê0 æ&v03 nLlyk=J[lô?:\$Xj,,?©/"•8(d••« æ{> 03•J(L 5Á,;ÿËkOš o

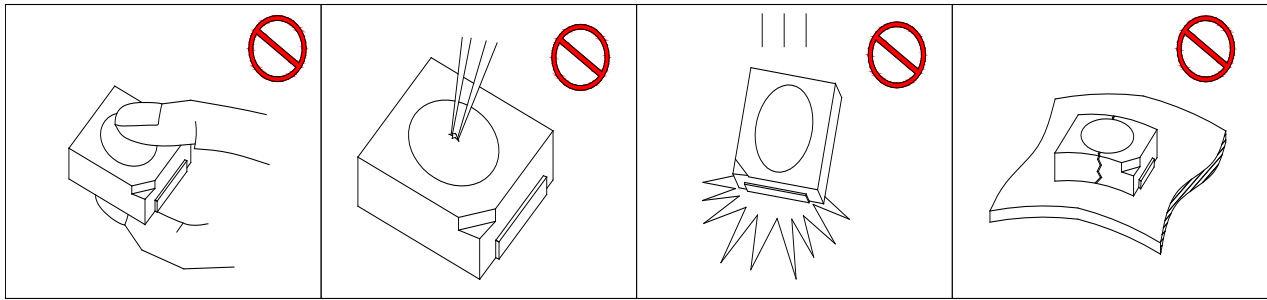

Fig 4-1 Cautions

(5) In designing a circuit, the current through each LED can not exceed the absolute maximum rating specified for each LED. In the mean while, resistors for protection should be applied, other wise slight voltage shift will cause big current change, burn out may happen. The driving circuit must be designed to allow forward voltage only when it is ON or OFF. If the reverse voltage is applied to LED, migration can be generated resulting in LED damage.

(6) Thermal Design is paramount importance because heat generation may result in the Characteristics decline, such as brightness decreased, Color change and so on. Please consider the heat generation of the LEDs when making the system design.

(7) Compared to standard encapsulants, silicone is generally softer, and the surface is more likely to attract dust, requiring special care during processing. In cases where a minimal level of dirt and dust particles cannot be guaranteed, a suitable cleaning solution must be applied to the surface after the soldering of components. Refond suggests using isopropyl alcohol for cleaning. In case other solvents are used, it must be assured that these solvents do not dissolve the package or resin. Ultrasonic cleaning is not recommended. Ultrasonic cleaning may cause damage to the LED.

Table 4-1 Storage *°=,

Conditions		Temperature	Humidity	Time
s+x«		^)CP	_*CP	Pž,,
Storage	Before Opening Aluminum Bag K.«-x	ö030 ë	ö075%	Within 1 Year From Date &gCf,;
	After Opening Aluminum Bag K.«0_	ö030 ë	ö060%	Recommended for use within 24 hours DŠ-ó24?-Pž,;({k=
Baking cwc•		60 p5 ë	-	ö124hours 8Đ'524?-Pž

(8) If the moisture absorbent material silica gel has faded away or the LEDs have exceeded the storage time, baking treatment should be performed after unpacking and based on the following condition 60 5 for above 24 hours. 9uSSC•e•klô.«'38ßOjæ{Iô•O'a1w&vux0V'Ä&sRcOj*°=, Rõ'Ýæ{ª=K.«0_•s•dcwc•æ{cwc•Rõ'Ýö; p ëæ{8Đ'5 ?-Pž o

If the package is flatulence or damaged, please notify the sales staff to assist. 9uSS.«'3€AElô•OpvL æ{—<ž oü\$H 2 'f0x/8. 8...i o

(9) Similar to most Solid state devices; LEDs are sensitive to Electro-Static Discharge (ESD) and Electrical Over Stress (EOS). *ø,&'-m, /1? (dkO=©4<'Ý&gTKæ{ - &?%ýkO•B](- tl« C"OuH-æ{ª='3* 9i"ÈJá o

(10) Other points for attention, please refer to our relevant information., &> \mH '2-à—</id'i°&ªnq,"™4Oñ o



REFOND

Declare KMPÉ

This specification is written both in English and in Chinese and the latter is formal.

'a1w" TT&ü'Ä&¥...%OÖP0D-84, W Rc, ~tr'Ä&¥OÖfR¥&&1, ¥